

Algorithms for computing fundamental categories, and applications to the static analysis of concurrent programs

Eric Goubault

CEA/Saclay

`Eric.Goubault@cea.fr`

`http://www.di.ens.fr/~goubault`

ATMCS II, London Ontario, 17th of july 2004

Plan

- Introduction (geometry of concurrency?)
- A construction of component categories (follow up of Martin's talk)
- Using component categories, for static analysis
- Some further remarks (if time permits...)

Geometry of concurrency?

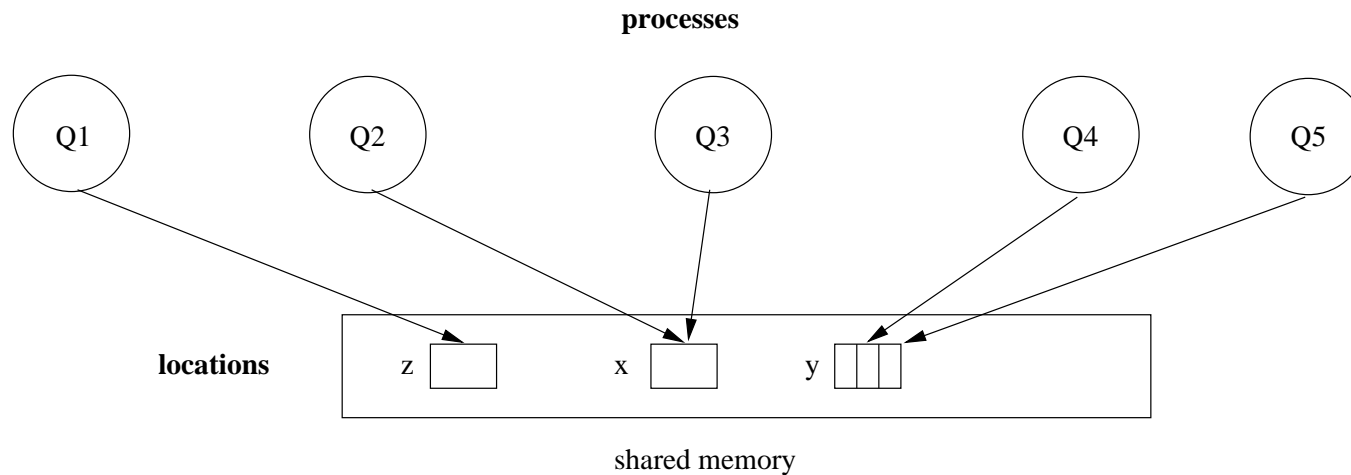

≠ sequential; coordination problems (locks P, V)

too constrained? → deadlocks

bad states? → reachability

“correct” access sequences? → paths...

First model

Processes: dynamical systems (discrete in general) = directed graphs of actions:

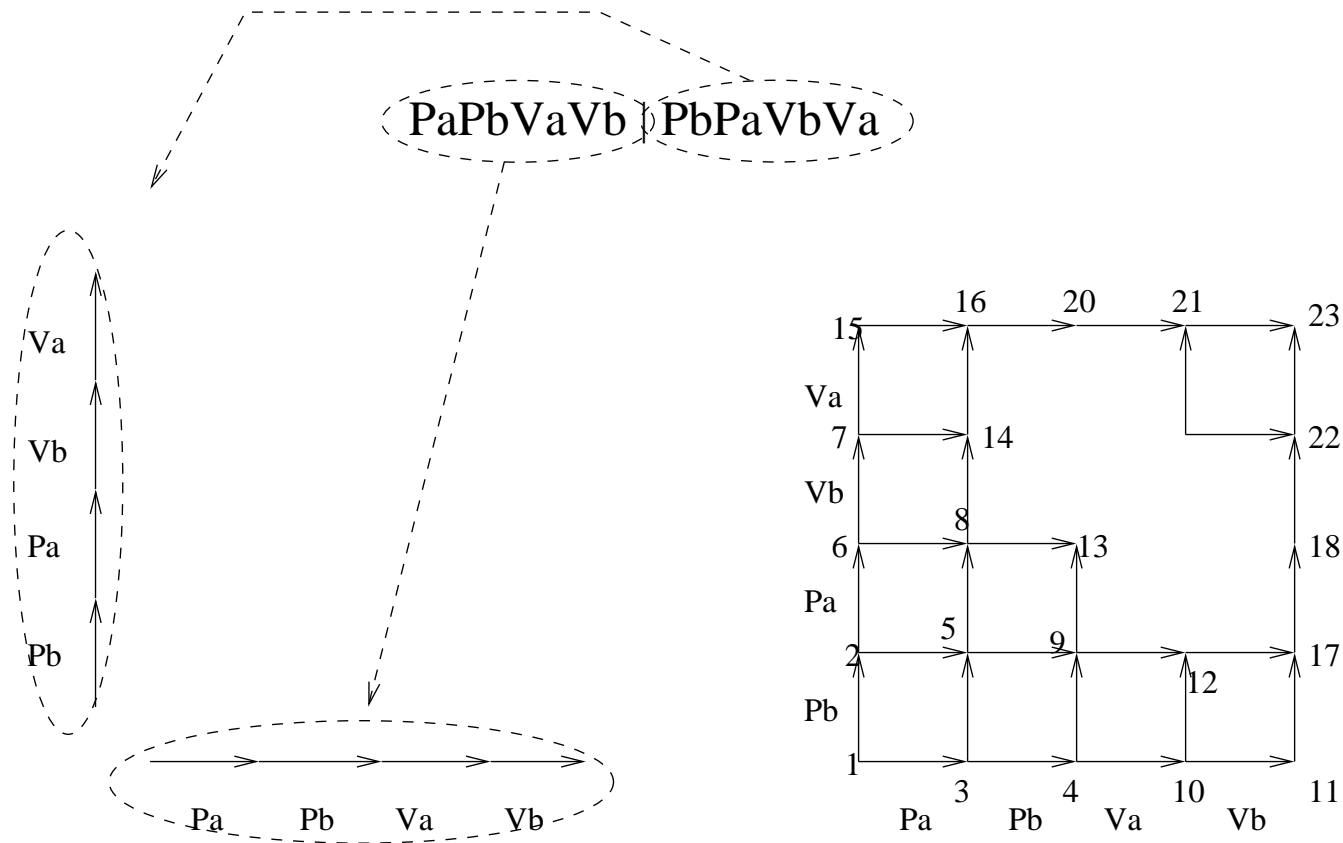

Example

Another potential execution (16 in total!):

T_1	T_2
Pa	—
Pb	—
—	$Pb(?)$
Va	—
Vb	—
—	Pa
—	Va
—	Vb

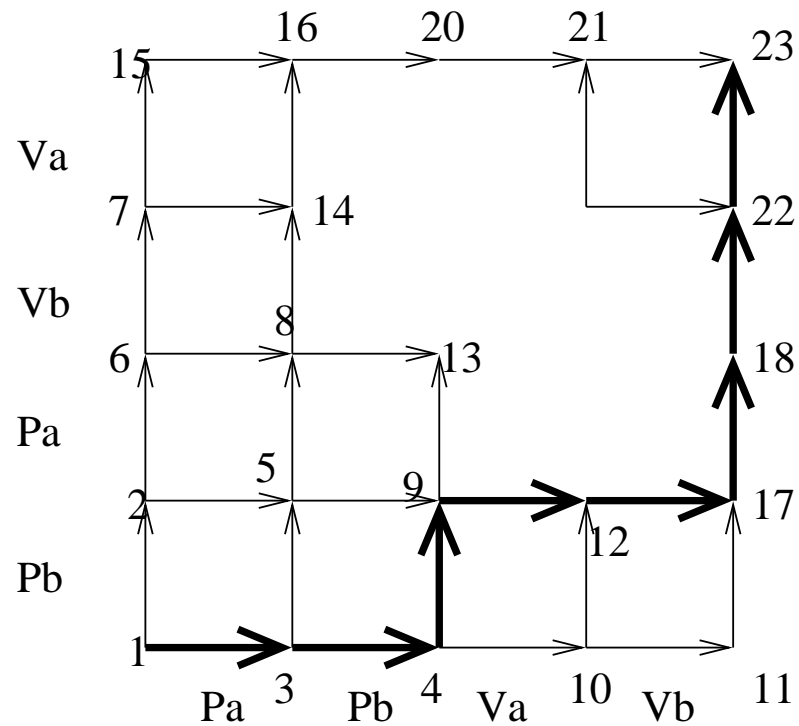

Notice that...

... there are very few “interesting” paths

Suppose, $T_1 = PaPb(b = b + 1)VaVb$ and $T_2 = PbPa(b = b * 2)VbVa$
and, in the beginning, $b = 2$:

- The 5 top left paths are “equivalent” to T_2 then T_1 : they compute $\underline{b = 5} (2*2+1)$
- The 5 bottom right paths are “equivalent” to T_1 then T_2 : they compute $\underline{b = 6} ((2+1)*2)$
- The 6 paths near the diagonal are equivalent: **they do not “terminate”**

In general, this is really painful...

Big number of states: here, Dekker's algorithm, a few lines of C on 2 processes, a few hundreds of paths, only 2 of which are interesting!

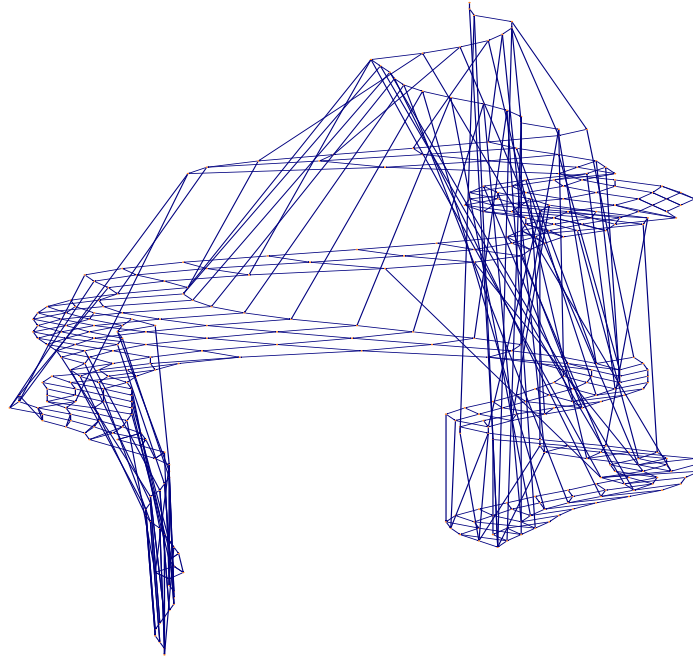

Geometry?

First idea: "Progress graphs" (E.W.Dijkstra (1968))

$T1=Pa.Pb.Vb.Va$ in parallel with $T2=Pb.Pa.Va.Vb$

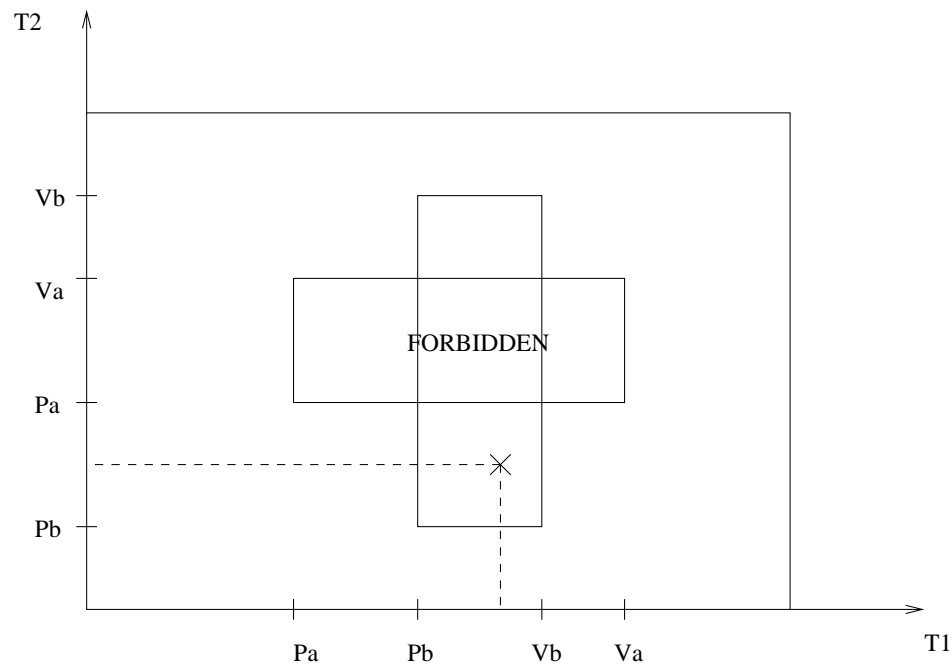

"Continuous image": $x_i =$ local time; dashed rectangles=forbidden!

Execution paths

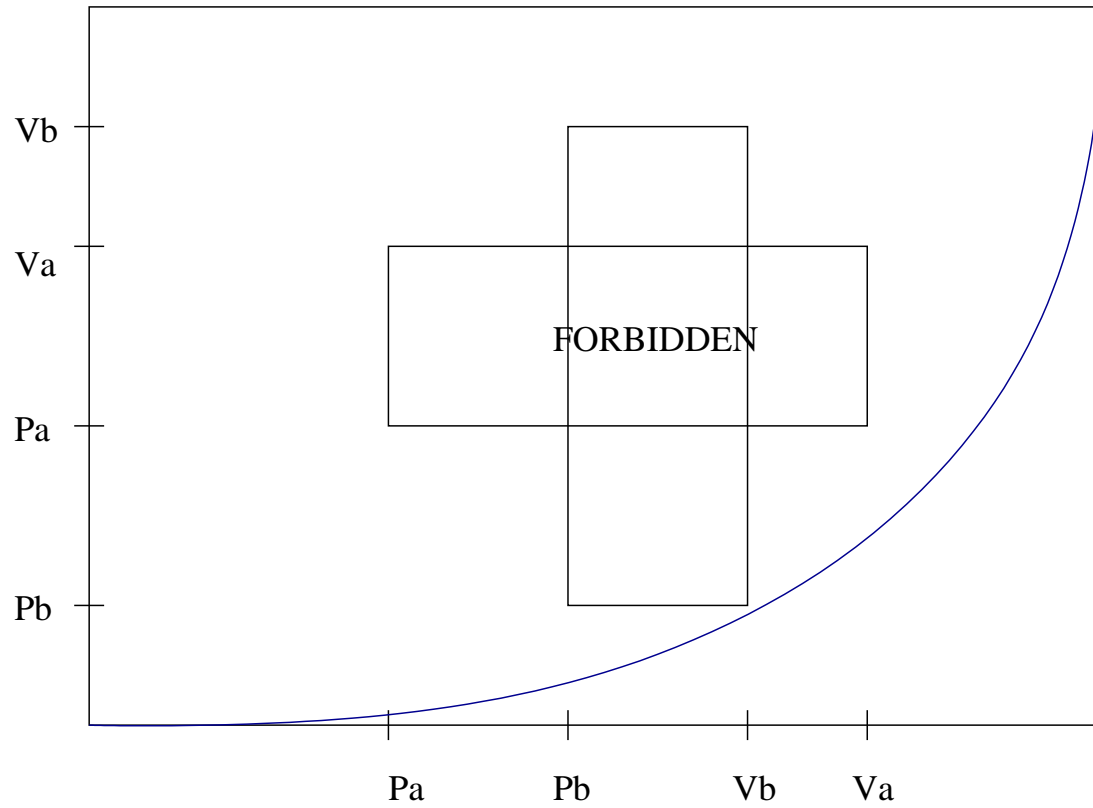

Traces = **continuous paths increasing** in each coordinate = “di-paths”

First remark

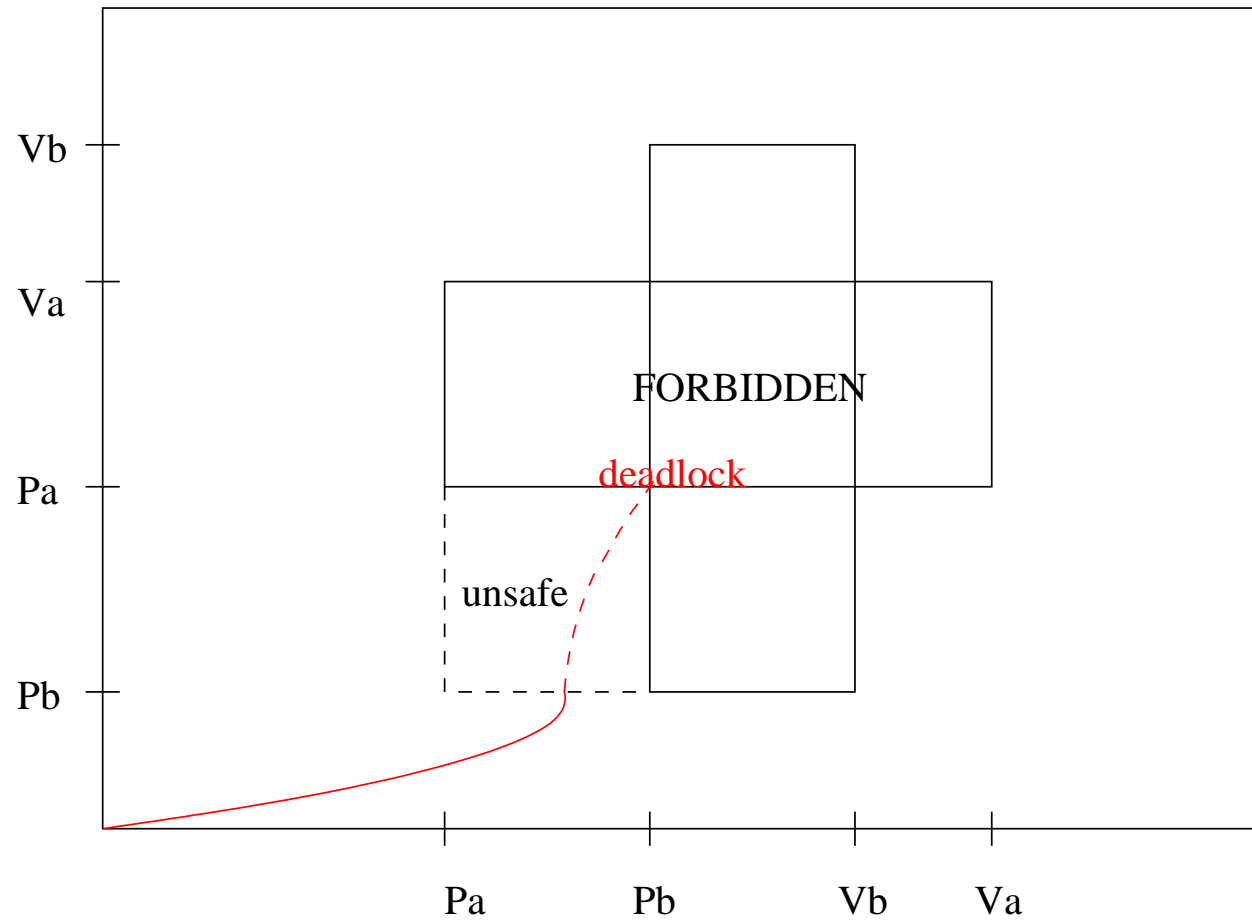

And dually...

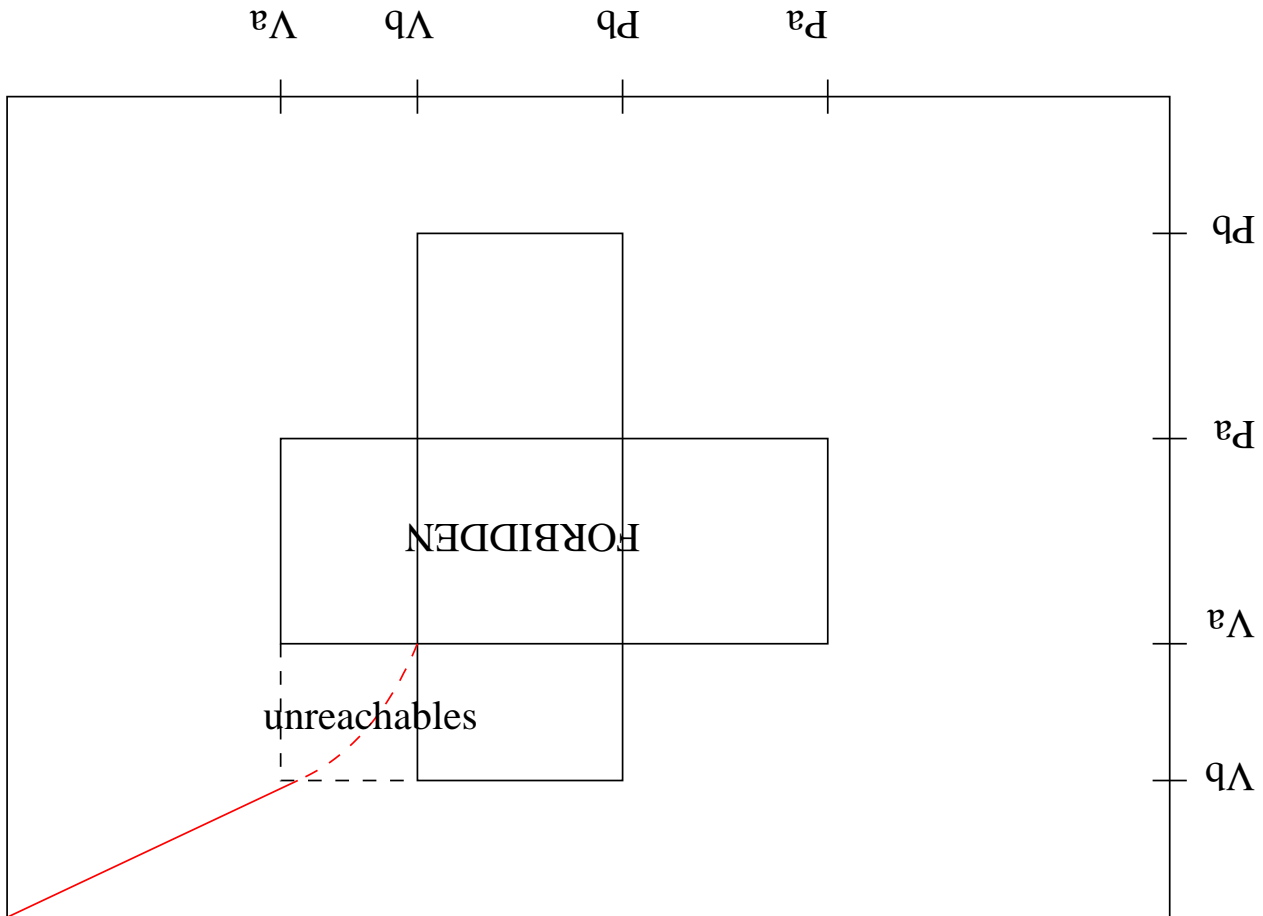

Deformation of execution traces

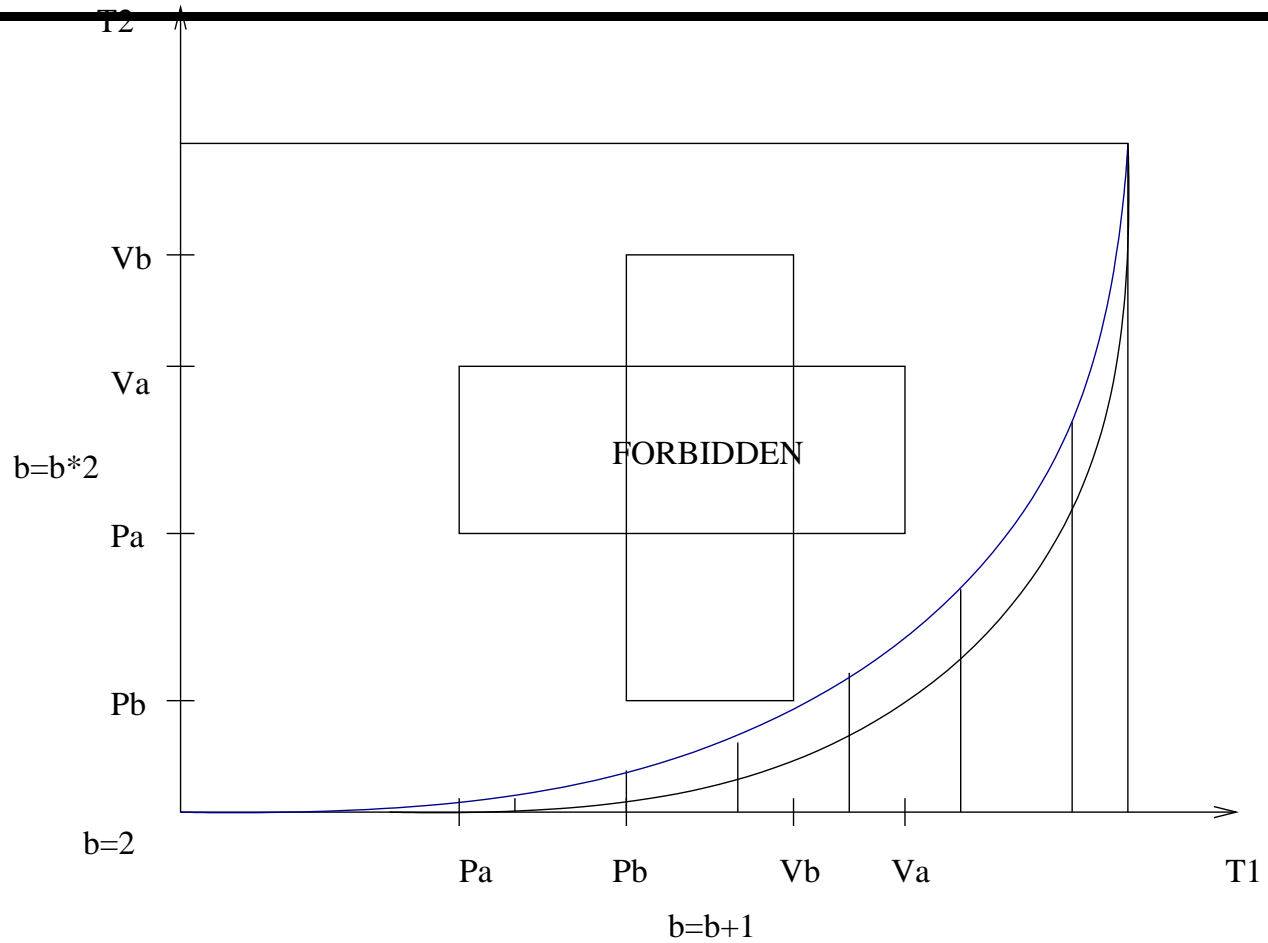

T1 gets a and b before T2 does: $b=6$

Non deformable paths

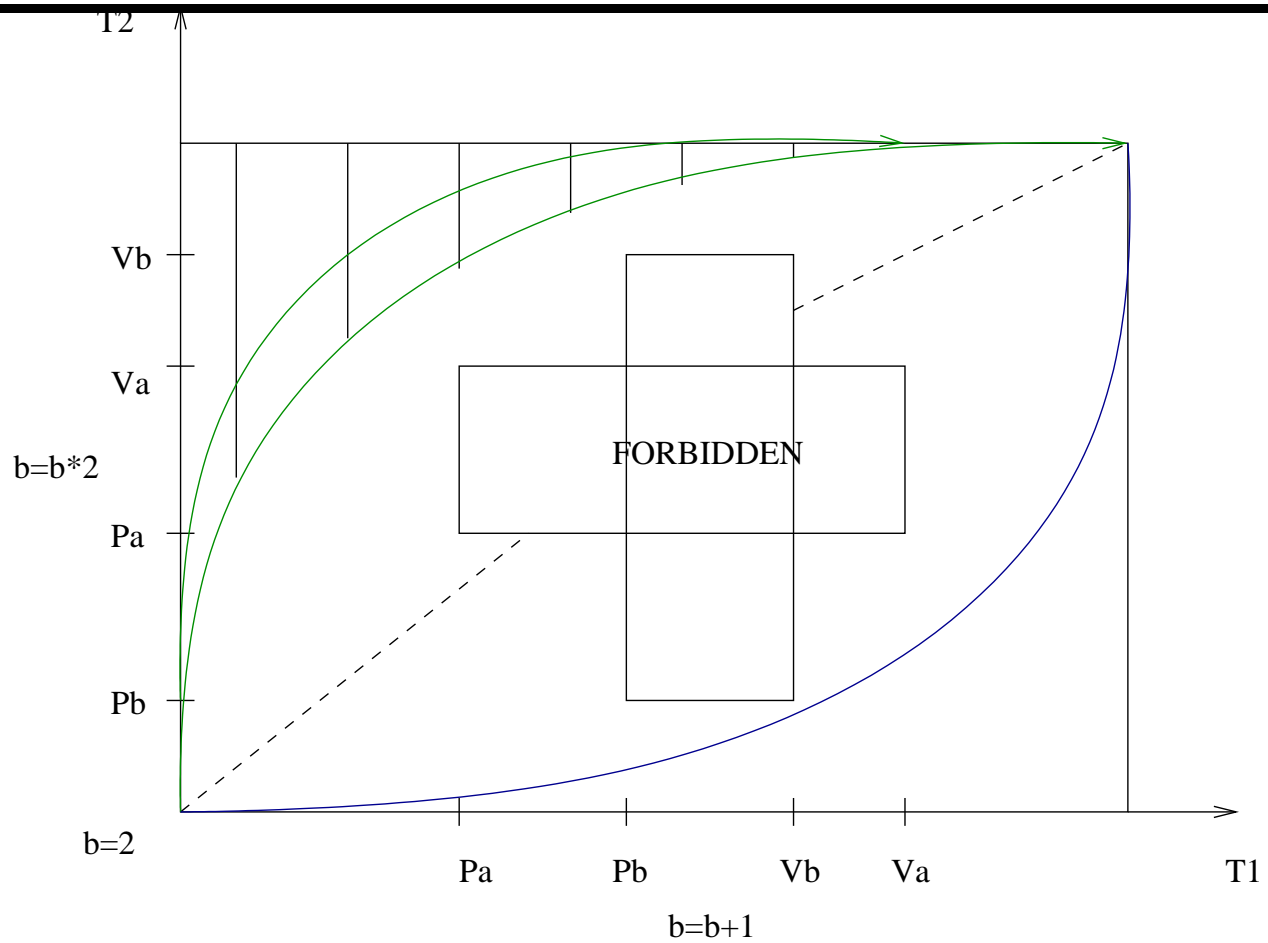

T2 gets a and b before T1 does: $b=5!$

Ideally (not quite true though)...

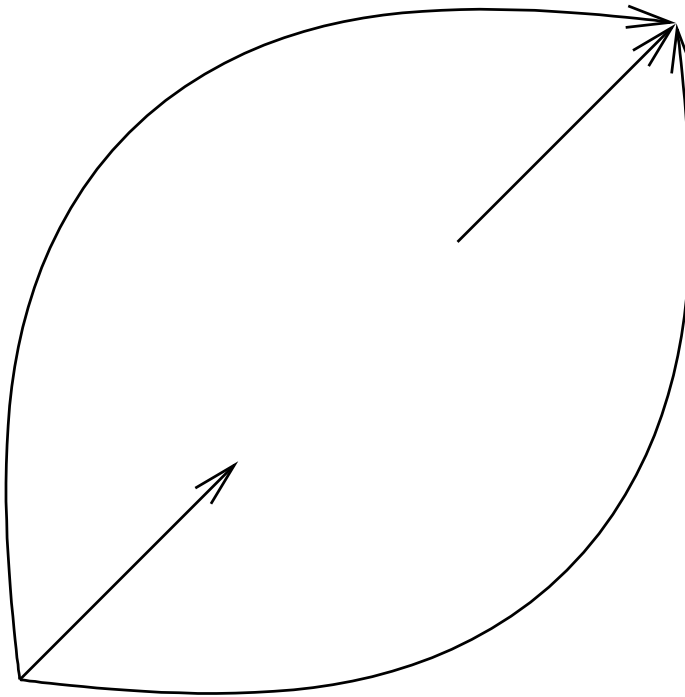

In higher dimension

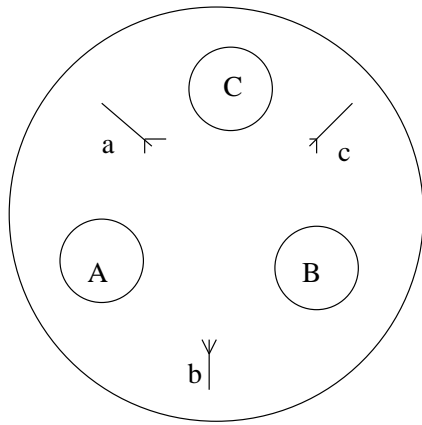

$$A = Pa \cdot Pb \cdot Va \cdot Vb$$

$$B = Pb \cdot Pc \cdot Vb \cdot Vc$$

$$C = Pc \cdot Pa \cdot Vc \cdot Va$$

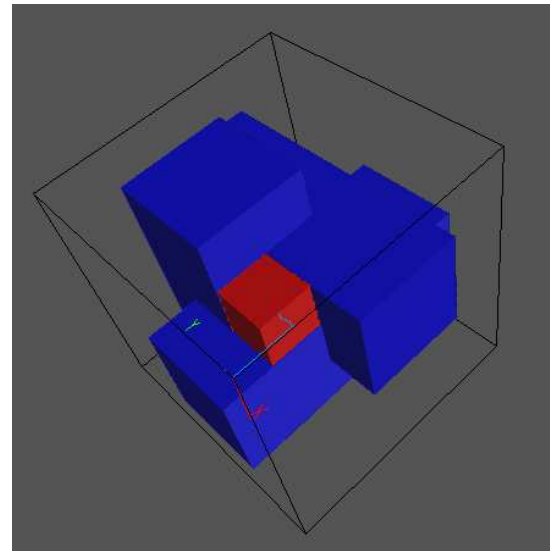
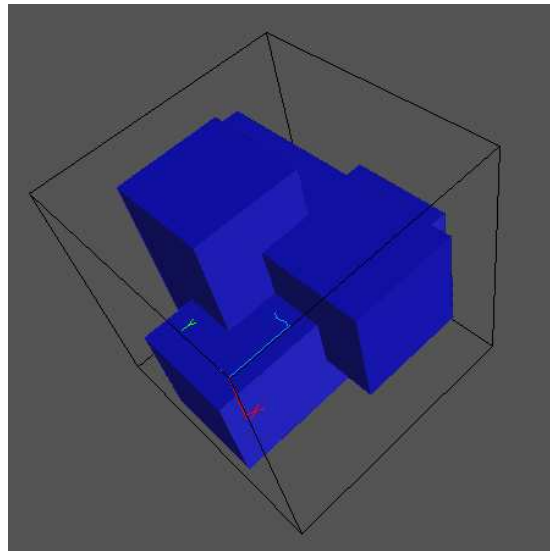

A counting semaphore

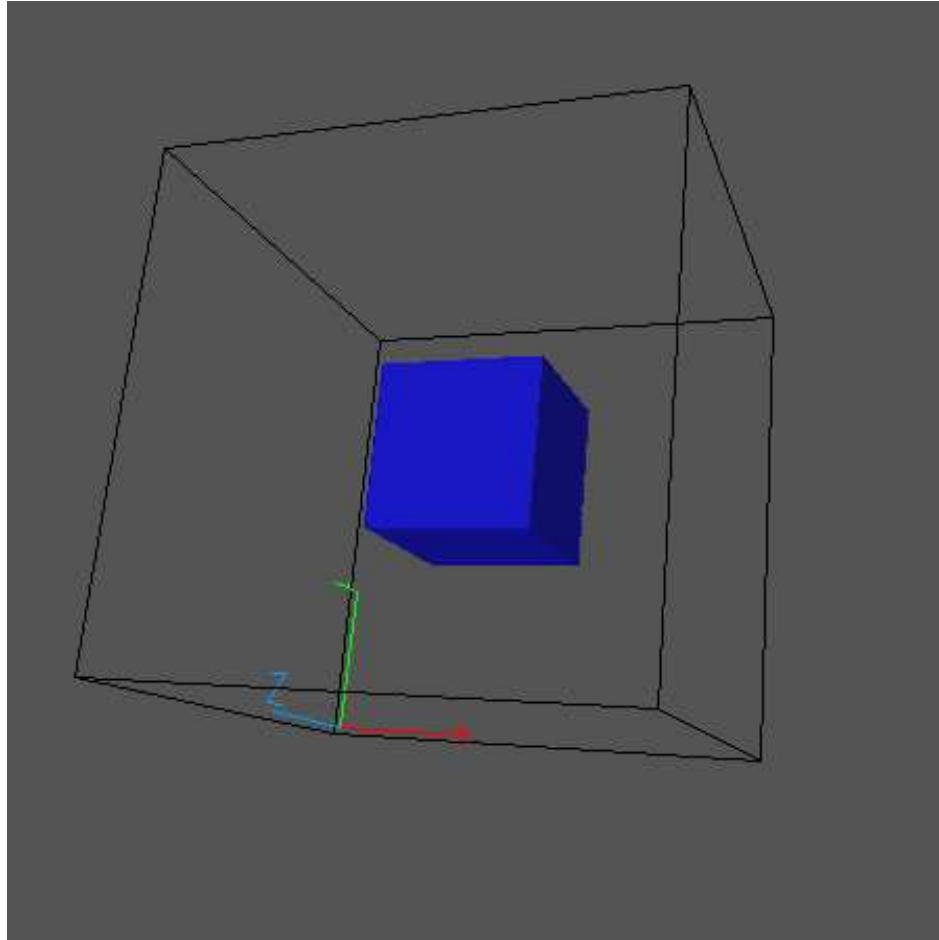

Loops?

$$A = Pd . Pa . (Pb . Va . Vd . Pc . Vb . Pa . Pd . Vc . Pb . Va . Pc . Vb . Pa . Vc . Pb . Va . Pc . Vb . Pa . Vc) * . Va . Pe . Vd . Ve$$

$$B = Pe . Pa . (Pb . Va . Pc . Vb . Pa . Vc . Pb . Va . Pc . Vb . Pa . Vc) * . Va . Pd . Ve . Vd$$

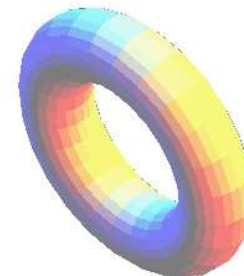
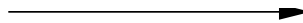
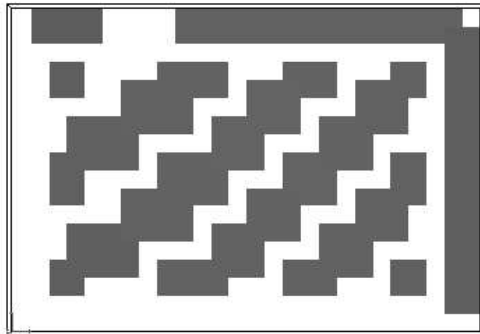

Gives...

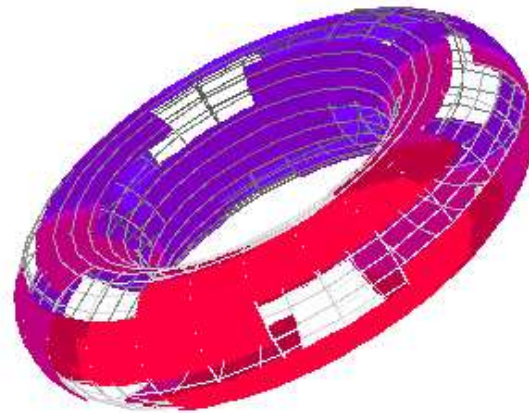

No deadlock, but 2 turns in the loop T_1 / 3 turns for T_2

Model [discrete]	combinatorial complex
Model [continuous]	topological space
Relation discrete/continuous	geometric realisation
Parallel composition	product
Action refinement	subdivision
Compositionality	Seifert/van Kampen
Deadlocks/reachability	connected components
Scheduling properties	fundamental group
Observational equivalence	homotopy equivalence (weak/strong)
Computable properties	topological invariants (homology etc.)
Models/Good structures	Quillen model categories

We are aiming at...

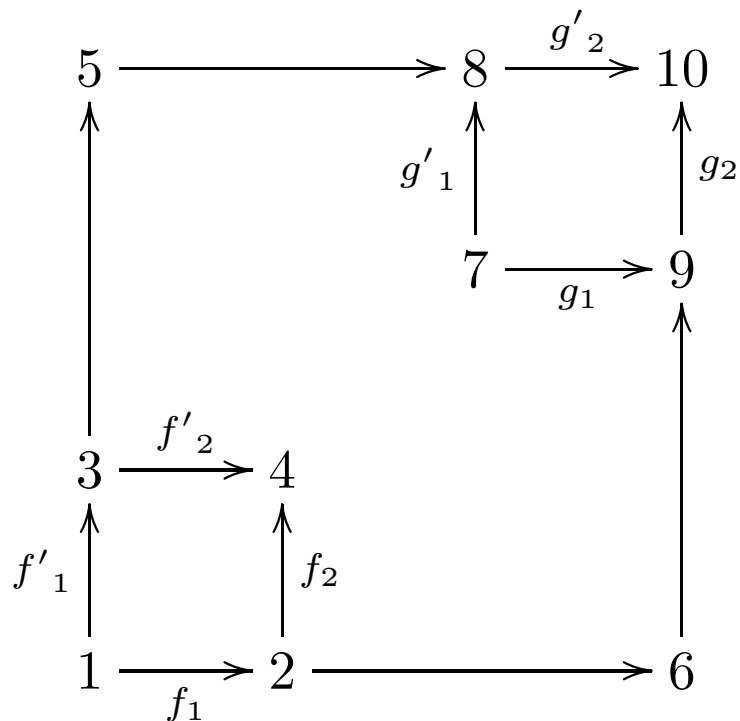
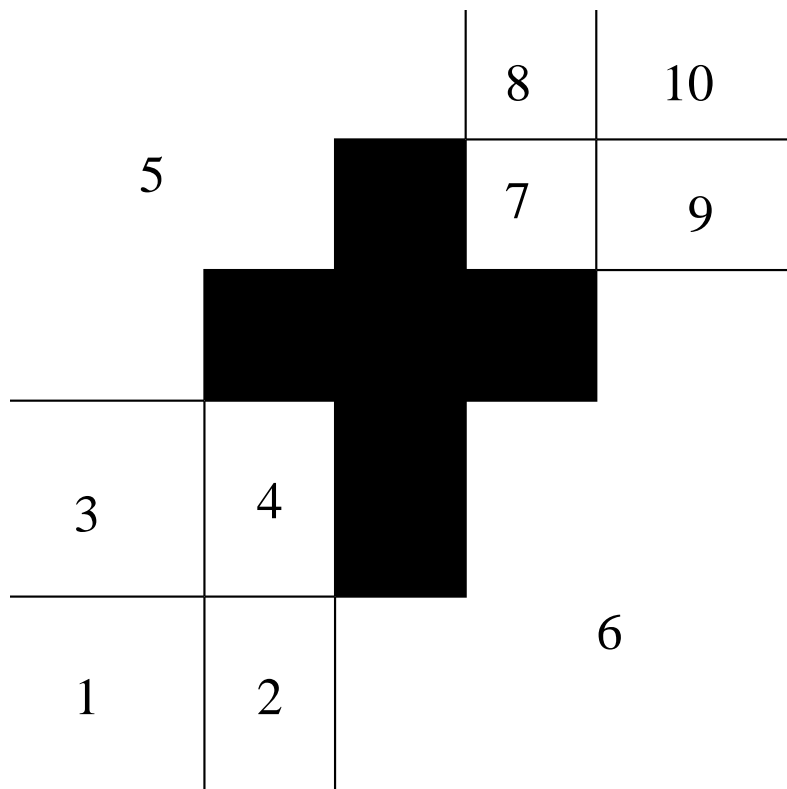

and the relations

$$g'_2 \circ g'_1 = g_2 \circ g_1 \text{ and}$$

$$f'_2 \circ f'_1 = f_2 \circ f_1$$

Future components

~~Let \mathcal{C} be a directed category. Σ is a subcategory of future weak equivalences (f -WE) if:~~

- Σ contains all isos of \mathcal{C} .
- all σ in Σ are epis in \mathcal{C} .
- Σ is stable under **pushout** (which always exists, with any morphism in \mathcal{C})^a.
- If there is $u : \beta \rightarrow \gamma$ in \mathcal{C} , then for all $\sigma : \alpha \rightarrow \beta$ in Σ , and all $f : \alpha \rightarrow \gamma$ in \mathcal{C} , f factors through σ , that is, there exists $h : \beta \rightarrow \gamma$ such that the following diagram commutes

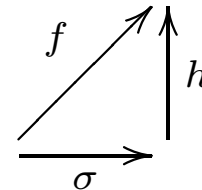

^aAlternative, weaker condition, by Lisbeth Fajstrup.

Duals and existence

- Dual notion p -WE, bi-notion WE .
- In **directed categories**, there always exists f -WE, p -WE and WE subcategories, namely the subcategory of isomorphisms of \mathcal{C} .

In general, nice framework: directed categories

- Let \mathcal{C} be a category, Σ a subcategory of \mathcal{C} . Σ is **pure** in \mathcal{C} if for all f, g in \mathcal{C} , $f \circ g \in \Sigma$ implies $f \in \Sigma$ and $g \in \Sigma$.
- A directed category is a category whose subcategory of isomorphisms is pure.
- For X a po-space, local po-space etc. $\vec{\pi}_1(X)$ is a directed category.

Important property

There exists a **maximal** one (the “optimal” state-space reduction)

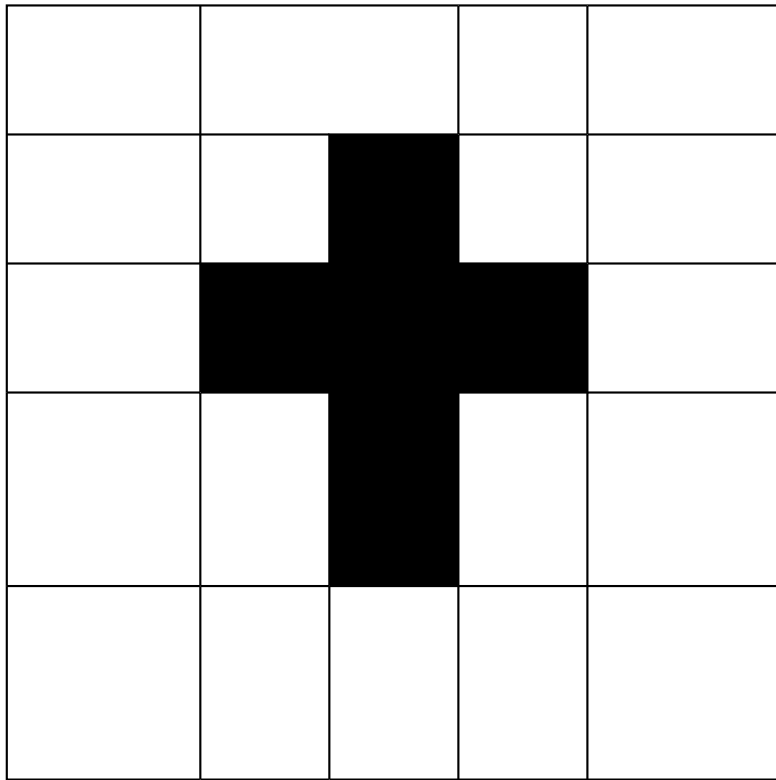

(interleaving - suboptimal)

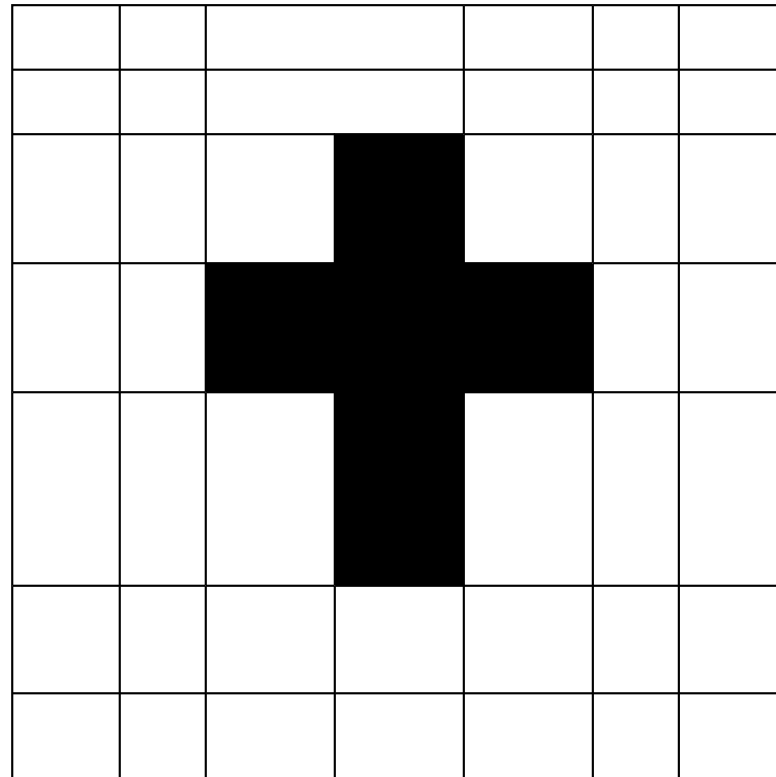

Maximal WE subcategories

Let \mathcal{C} be a directed category. There exists a maximal subcategory of WE (f -WE, p -WE respectively) in \mathcal{C} .

Sketch of proof.

There exists one, as we saw earlier.

Now, it suffices to show that if τ is a morphism of \mathcal{C} satisfying all axioms of a subcategory of WE (as the category generated by τ) and if Σ is a subcategory of WE, then all composites $\tau \circ \sigma$ and $\sigma \circ \tau$, together with Σ , is a subcategory of WE. By induction, we see that being WE is inductive. Using Zorn's lemma, we find the maximal WE.

WE and left/right calculi

- p -WE form right calculi, and
- f -WE form left calculi,
- WE form **left and right** calculi.

Sketch of proof.

It is immediate to see that the fact that all σ in Σ are monos imply (iv). Then having pullbacks between any σ in Σ and f in \mathcal{C} trivially implies the extension property (iii).

Purity

Let Σ be a subcategory of WE (respectively, f -WE, p -WE) in \mathcal{C} , then Σ is (respectively left, right) **pure**.

Sketch of proof.

Suppose σ in Σ is equal to $f_2 \circ f_1$ with f_1 and f_2 in \mathcal{C} :

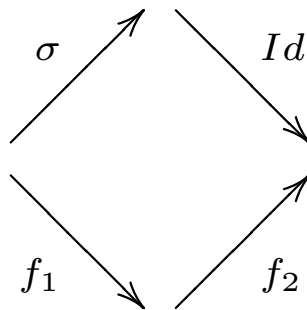

Sketch of proof

As σ is in Σ , we have a pushout between σ and f_1 , hence we have the commutative diagram

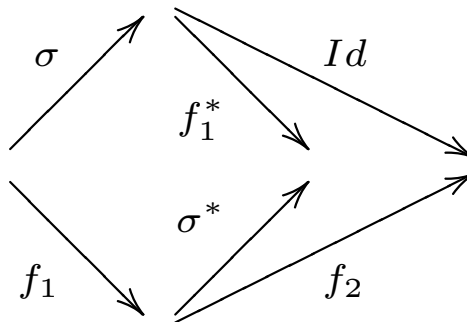

Sketch of proof

hence, by the universality of the pushout, we have a unique h in \mathcal{C} such that the diagram below commutes

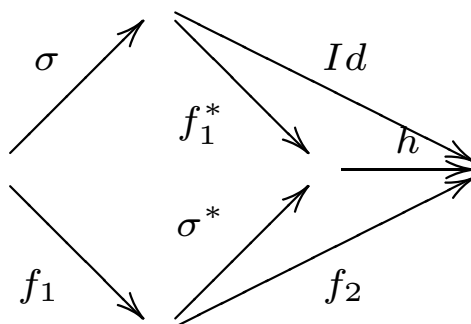

This implies that $Id = h \circ f_1^*$. Hence Id (an iso) is factored - by purity of isos in directed categories, h and f_1^* are isos. Hence h is in Σ . This also implies that $f_2 = h \circ \sigma^*$, a composite of two elements of Σ , hence is in Σ .

Sketch of proof

Now we can rewrite $\sigma = f_2 \circ f_1$ as the commutative diagram

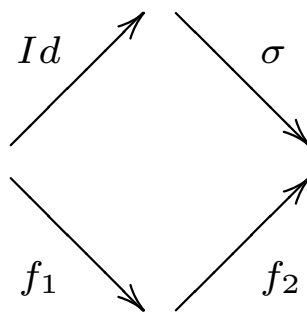

and use the universal property of the pullback of σ along f_2 , to conclude in the same manner that f_1 is in Σ .

Consequence...

~~Using the maximal WE, we have all the results from APCs (see Martin's talk), and in particular:~~

Let \mathcal{C} be a category in which all endomorphisms are identities. Then there is a maximal WE subcategory Σ in \mathcal{C} . Furthermore, let $C_1, C_2 \subset Ob(\mathcal{C})$ denote two components such that the set of morphisms (in \mathcal{C}/Σ) is *finite*^a. Then, for every $x_1 \in C_1$ there exists $x_2 \in C_2$ such that the quotient map

$$\mathcal{C}(x_1, x_2) \rightarrow \mathcal{C}/\Sigma(C_1, C_2), \quad ; \quad f \mapsto [f]$$

is *bijective*.

Similarly with just *f*-WE (we can choose the target point only) and the *p*-WE (we can choose the source point only).

^aIf we ask for a little more on Σ , no restriction here!

How can we solve the problem...

... of the characterisation of the schedulings (or “essential” traces)?

- By applying some general theorems ([van Kampen](#), see E. Haucourt’s [CEA & Paris 7] work etc.)
- By some [specific](#) algorithms (in the case of \mathbf{R}^n): implemented, with some algorithmic improvements to come.

Component categories generated by bidimensional cubical sets

For the mutual exclusion case ($X = I \xrightarrow{n} R$), the component category is generated by a **bidimensional cubical set**.

$$F : \Upsilon_2 \rightarrow \mathcal{C}$$

- let D be the free category generated by the graph (X_0, X_1) underlying X .
- $F(X)$ is the quotient of D by relations:
 $[d_0^1(A)] \circ [d_1^0(A)] = [d_1^1(A)] \circ [d_0^0(A)]$ where $A \in X_2$ is a 2-cell.

A simple case

The component category for the following program:

$$A = Pa \cdot Va$$

$$B = Pa \cdot Va$$

$$\text{PROG} = A \mid B$$

is given by the following picture:

Simple case

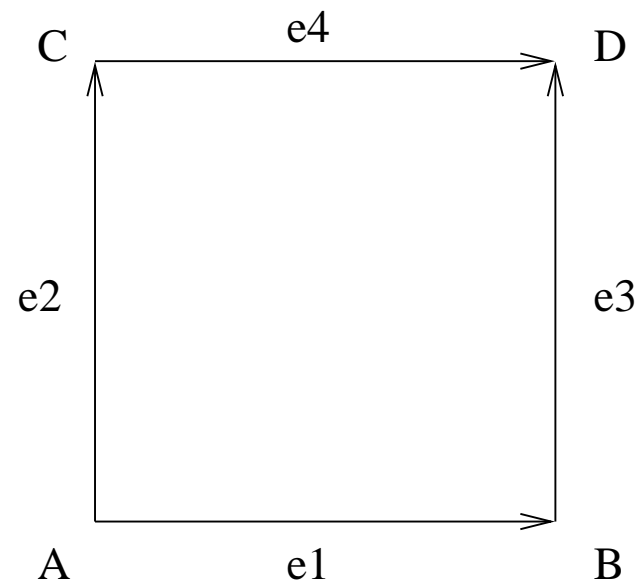
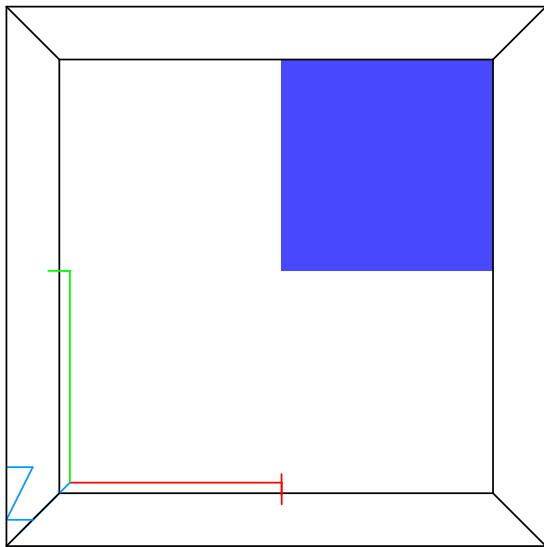

The component category, geometrically

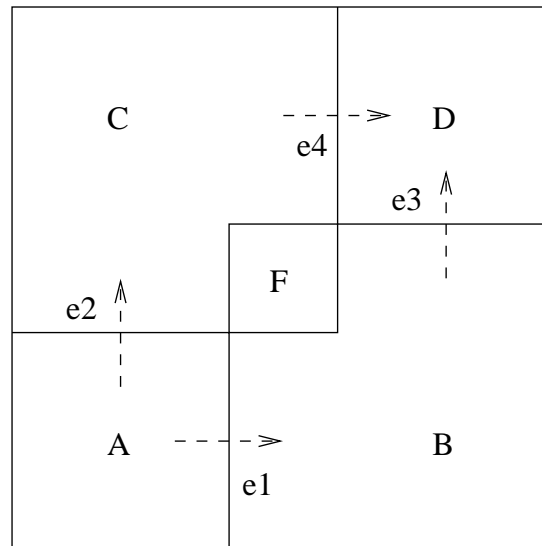

The components A , B , C and D correspond to the squares separated by the horizontal and vertical lines from the min and max points of the forbidden region F .

The component category: “duality”

- The unique morphism from A to B (e_1) is the “orthogonal” of the vertical line coming from the min point of F .
- We identify e_1 with the codimension 1 linear variety (here, the vertical segment)
- Similarly, e_2 is identified with the horizontal line left of the min point of F etc.
- There is no interesting codimension 2 linear variety here, hence no relations between morphisms.

Digging a hole

This corresponds here to the program:

$$A = Pa . Va . Pb . Vb$$

$$B = Pb . Vb . Pa . Va$$

$$\text{PROG} = A \mid B$$

and the component category is:

Component category

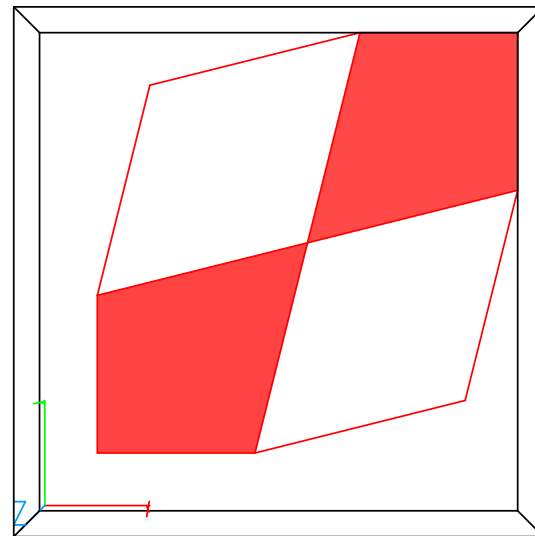
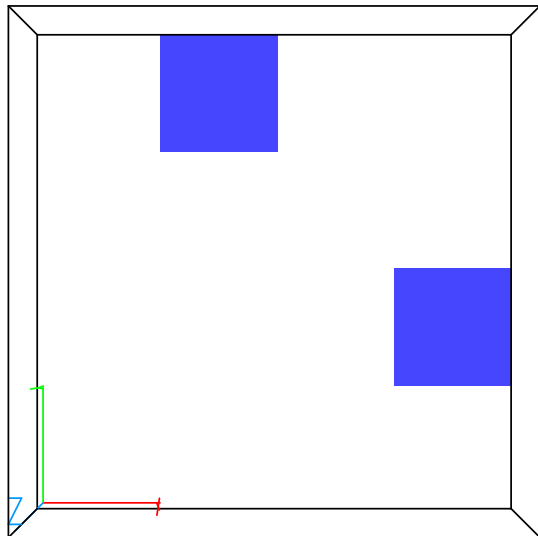

Inductive formula

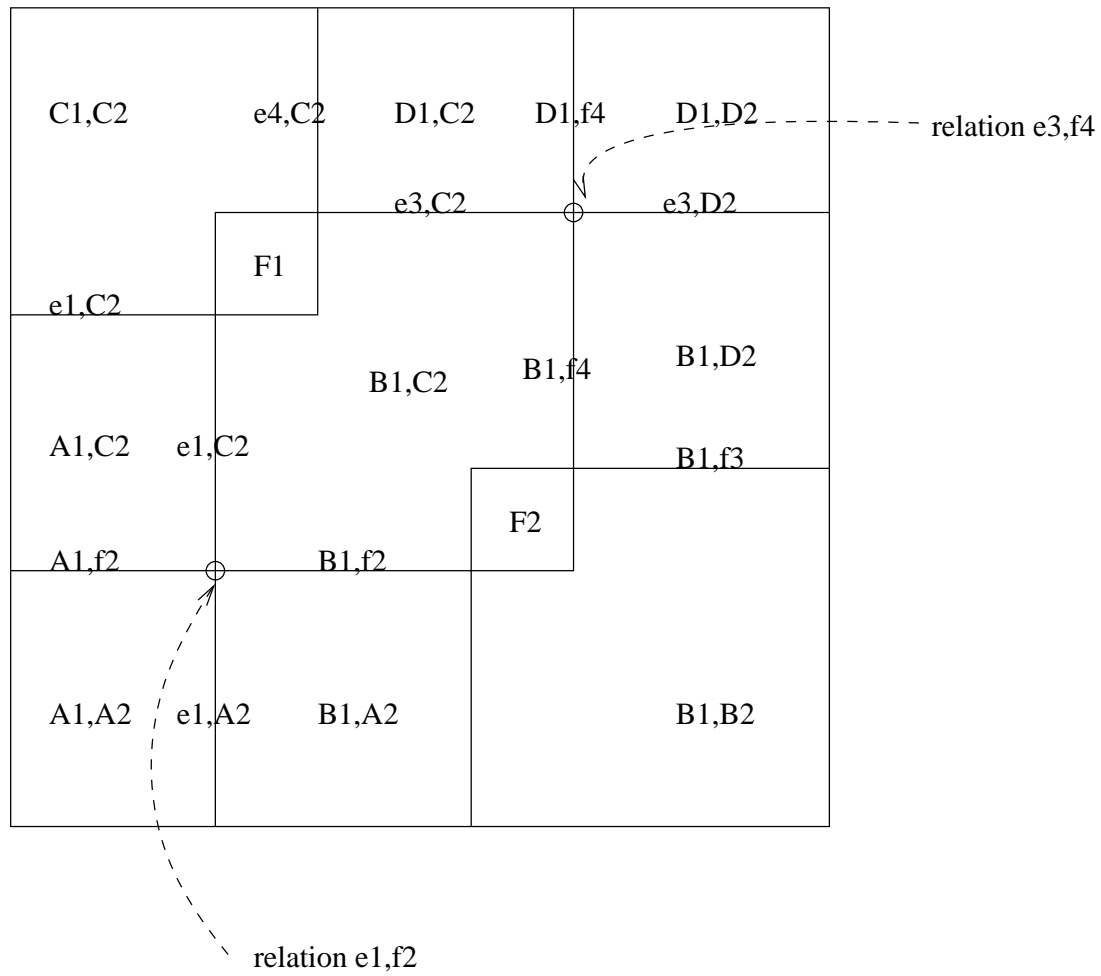

Inductive formula

Inductive formula: based on the **intersections** of codimension 0, 1 and 2 linear varieties, for all holes dug:

- Starting with (e_1, e_2, e_3, e_4) (for F_1) and (f_1, f_2, f_3, f_4) (for F_2)
- We compute all intersections of objects (regions) (A_1, B_1, C_1, D_1) with morphisms of F_2 and of morphisms of F_1 with objects (A_2, B_2, C_2, D_2) of F_2
- We have for instance the **relation** (e_1, f_2) (intersection of two morphisms):

$$(e_1, C_2) \circ (A_1, f_2) = (B_1, f_2) \circ (e_1, A_2)$$

Let us dig again...

...in order to compute the component category of:

$$A = Pa . Va . Pb . Vb . Pc . Vc$$

$$B = Pc . Vc . Pb . Vb . Pa . Va$$

$$\text{PROG} = A \mid B$$

Component category

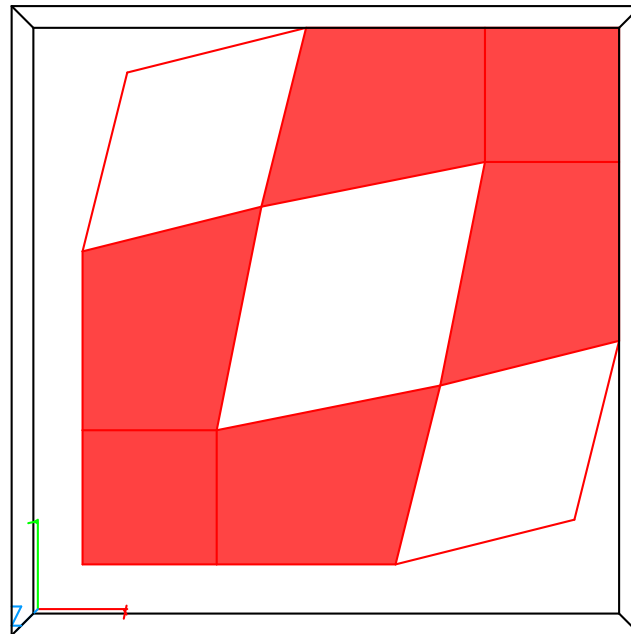

Inductive “explanation”

The six relations we find are given in the picture (g_1, g_2, g_3 and g_4 are the morphisms of the component category of F_3 alone).

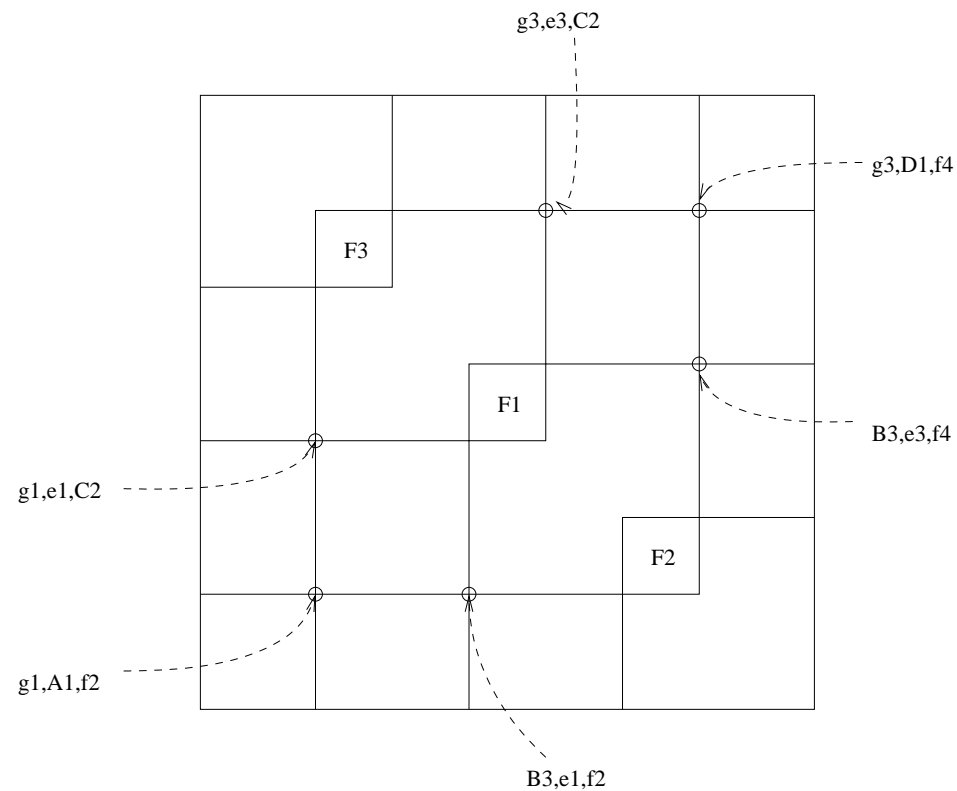

2 semaphore

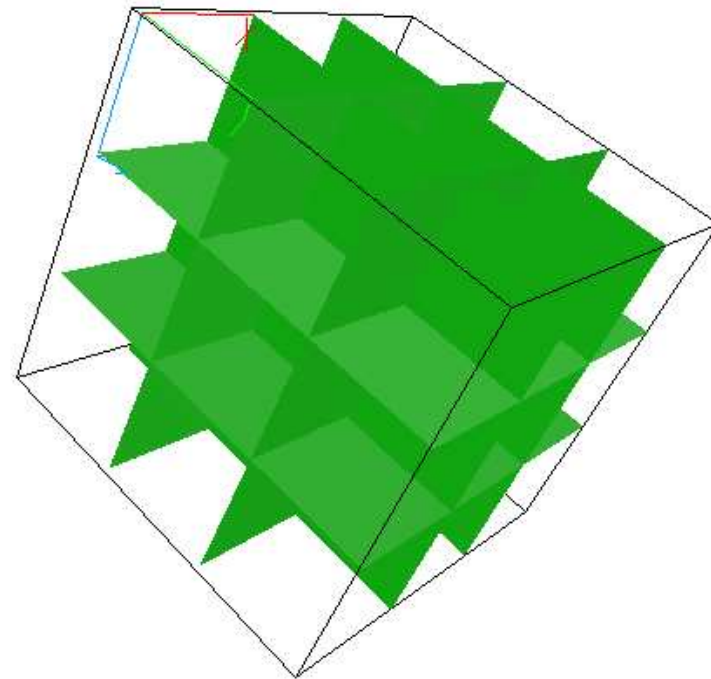
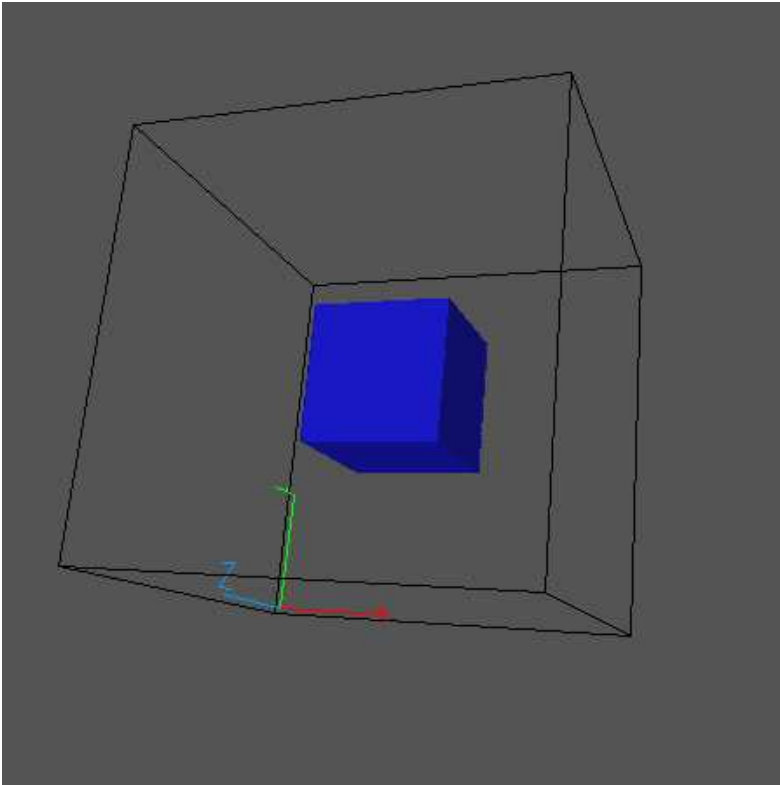

Inductive presentation of the component category

We already know that the component category of $[0, 1]^n \setminus R$ is generated by a 2-dimensional precubical set, that we write as $(Y_0, Y_1, Y_2, \delta^0, \delta^1)$. We now define a new structure $(Z_0, Z_1, Z_2, \partial^0, \partial^1)$ which will generate (an “approximation” of) the component category of $U \setminus R$:

- $Z_0 = \{A \cap B \mid A \in X_0, B \in Y_0, A \cap B \neq \emptyset\}$
- $Z_1 = \{A \cap f \mid A \in X_0, B \in Y_1, A \cap f \neq \emptyset\} \cup \{e \cap B \mid e \in X_1, B \in Y_0, e \cap B \neq \emptyset\}$

Inductive presentation of the component category

$$\{e \cap f \mid e \in X_1, f \in Y_1, e \cap f \neq \emptyset\}$$

- $Z_2 = \cup\{R \cap B \mid R \in X_2, B \in Y_0, R \cap B \neq \emptyset\}$

$$\cup\{A \cap S \mid A \in X_0, S \in Y_2, A \cap S \neq \emptyset\}$$

- $\partial_*^* : Z_1 \rightarrow Z_0$ are defined by:

- $\partial_0^0(A \cap f) = A \cap \delta_0^0(f),$

- $\partial_0^1(A \cap f) = A \cap \delta_0^1(f),$

- $\partial_0^0(e \cap B) = d_0^0(e) \cap B,$

- $\partial_0^1(e \cap B) = d_0^1(e) \cap B.$

Inductive presentation of the component category

- $\partial_*^* : Z_2 \rightarrow Z_1$ are defined by:
 - $\partial_0^0(e \cap f) = d_0^0(e) \cap f,$
 - $\partial_1^0(e \cap f) = e \cap \delta_0^0(f),$
 - $\partial_0^1(e \cap f) = d_0^1(e) \cap f,$
 - $\partial_1^1(e \cap f) = e \cap \delta_0^1(f),$
 - $\partial_l^k(R \cap B) = d_l^k(R) \cap B$ (for $k, l = 0, 1$),
 - $\partial_l^k(A \cap S) = A \cap \delta_l^k(S).$

The 3 philosophers

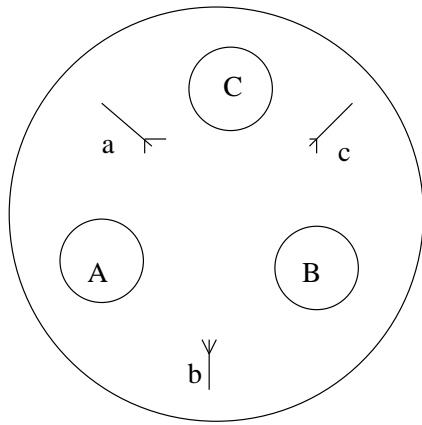

A=Pa . Pb . Va . Vb

B=Pb . Pc . Vb . Vc

C=Pc . Pa . Vc . Va

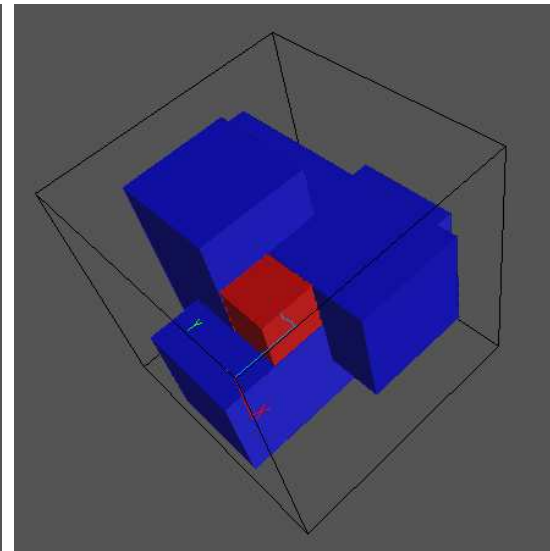
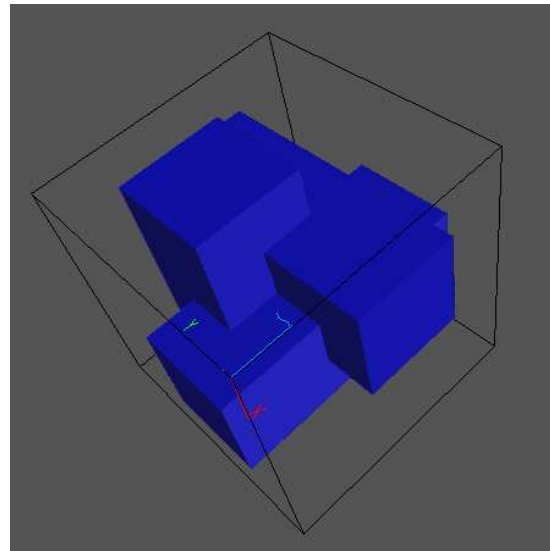

Component category

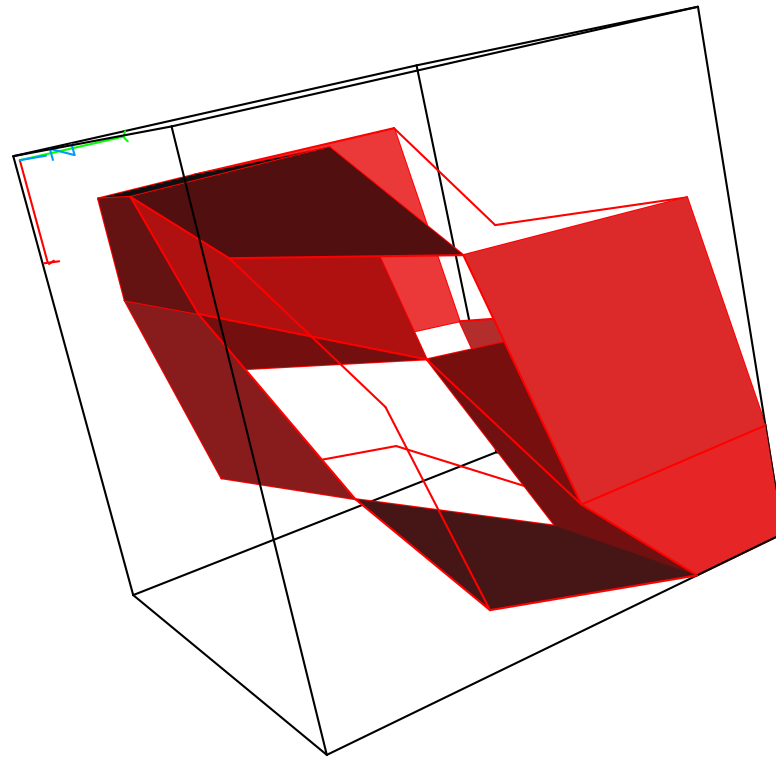

Example

In the case of the 3 philosophers, we find 6 ($=3!$) maximal legal paths (all possible serializations in fact):

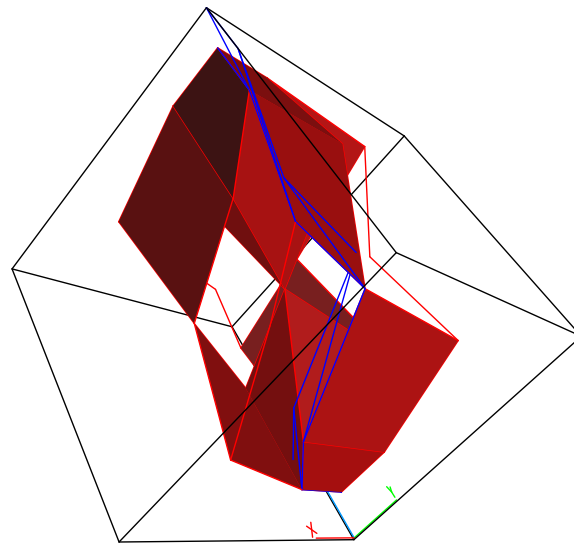

Path 3

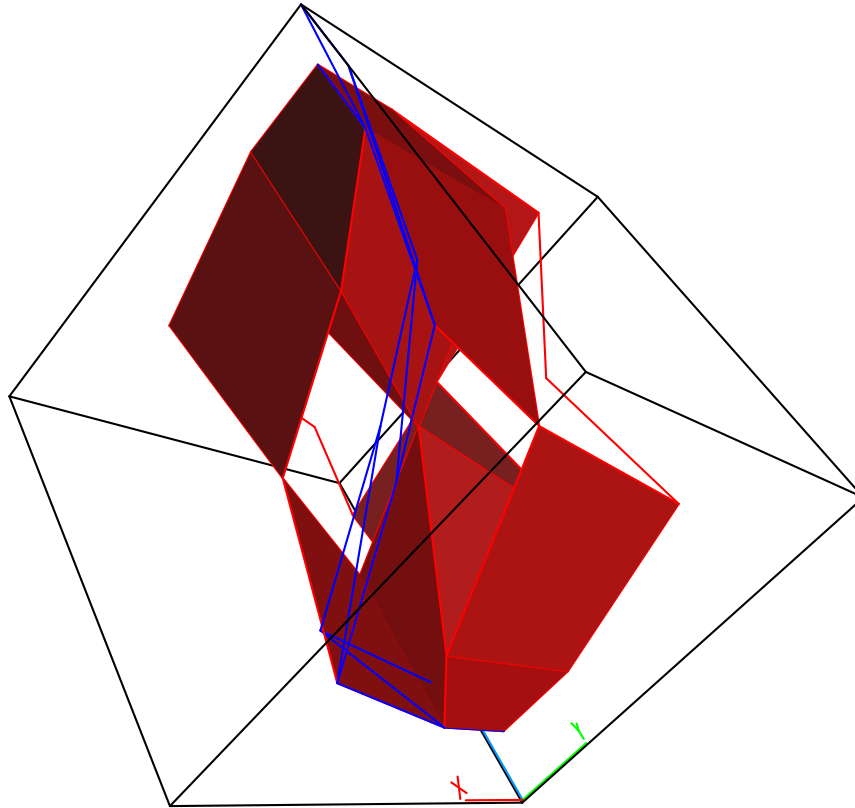

Path 4

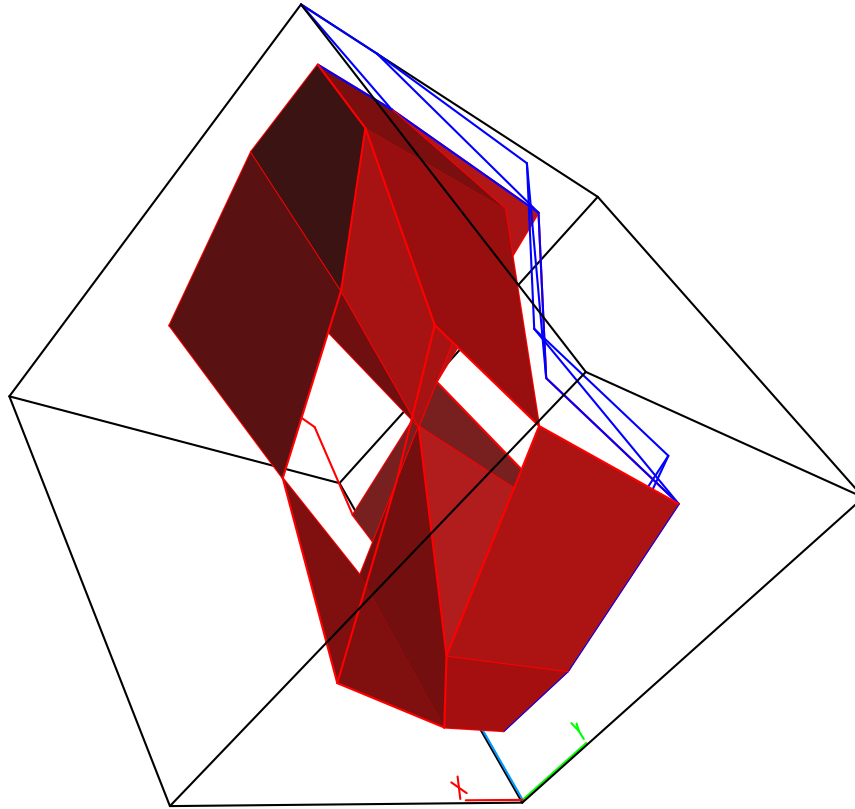

Path 5

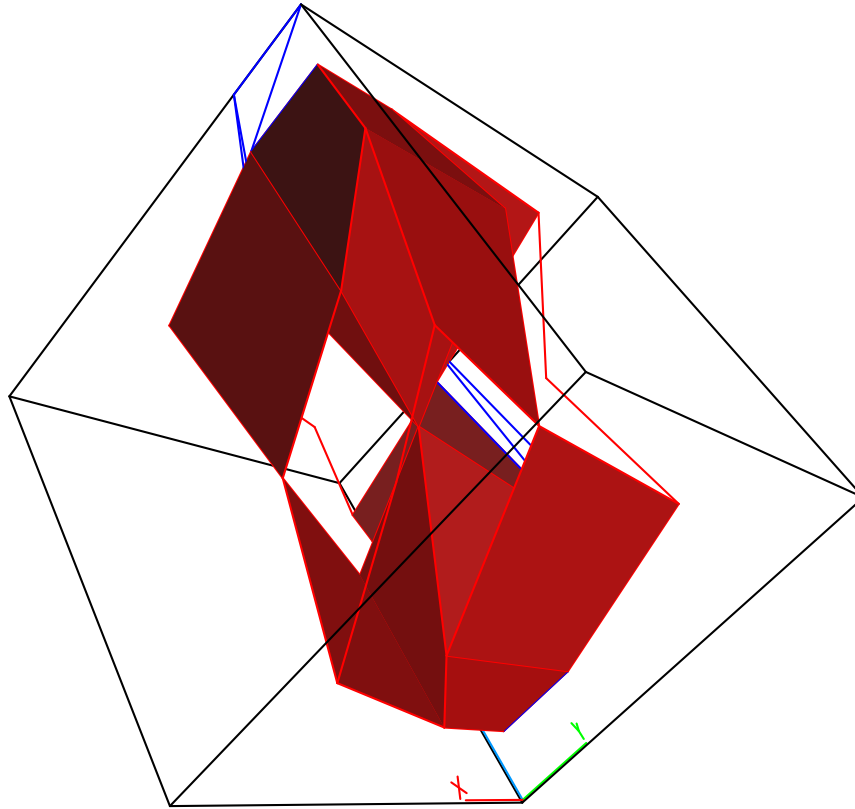

Path 6

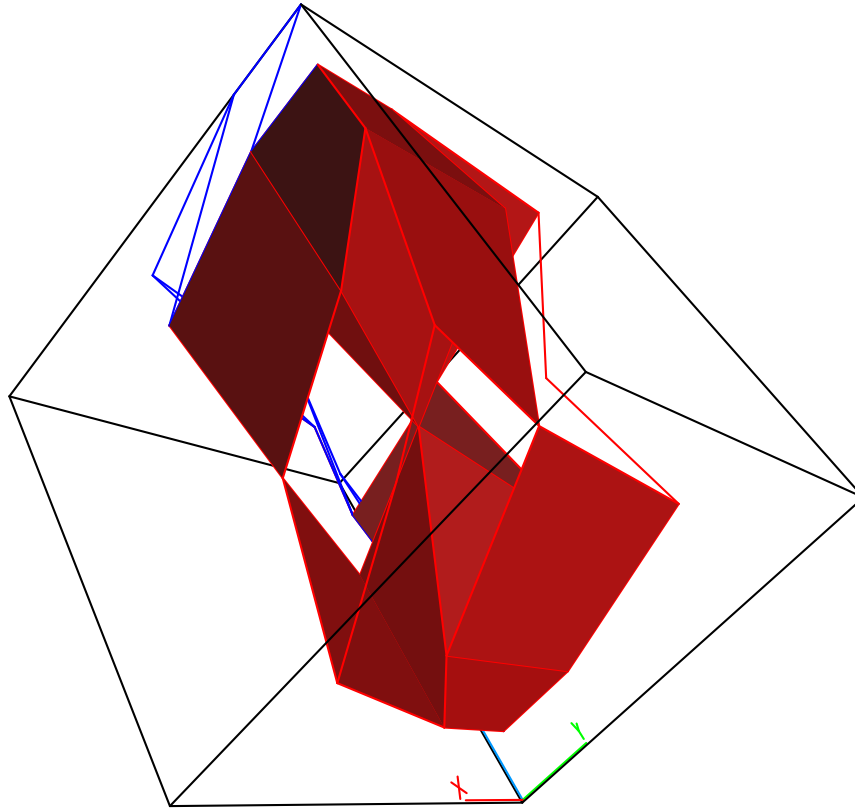

Some figures...

- new3phil.pv: (0.05s) Objects: 27, Morphisms: 48, Relations: 18
- new4phil.pv: (0.07s) Objects: 85, Morphisms: 200, Relations: 132
- new7phil.pv: 4s; 42 Mo; (about one million transitions in a standard model) Objects: 2467, Morphisms: 10094, Relations: 15484
- new8phil.pv: 21s; 100Mo; (about 10 million transitions in a standard interleaving model) Objects: 7533, Morphisms: 35216, Relations: 64312
- new9phil.pv: 106s, 319Mo (about 100 million transitions in a standard model) Objects: 22995, Morphisms: 120924, Relations: 256158 for $9!=362880$ maximal paths...

Syntactic representation of a path...

...or how to choose a “good” lift:

- From a continuous path, we want to get back to a “discrete” path
- This “discrete” path is an **interleaving** path corresponding to this idealized execution
- This can be then analyzed by any standard **sequential analyzer**

Example

```
> more simple.pv
A=Pa.Va.Pb.Vb
B=Pb.Vb.Pa.Va
PROG=A|B
> essentialpaths simple.pv
(...)
Number of paths=3
```

Example

```
> more simple.pv_1.sp
{1}P(a);{1}V(a);{1}P(b);{1}V(b);{2}P(b);
  {2}V(b);{2}P(a);{2}V(a);
> more simple.pv_2.sp
{2}P(b);{2}V(b);{2}P(a);{2}V(a);{1}P(a);
  {1}V(a);{1}P(b);{1}V(b);
> more simple.pv_3.sp
{1}P(a);{2}P(b);{1}V(a);{2}V(b);{2}P(a);
  {2}V(a);{1}P(b);{1}V(b);
```

For this...

We remark that:

- (1) Every component has a **trivial** $\vec{\pi}_1$
- (2) There exists a path (unique) from the **minimum** (or infimum in general) from a component to the minimum of the next component (essentially by the lifting property)
(modulo some technicalities I am hiding here...)

For this...

Given the morphisms of the component category, we compute:

- (a) the minimum of the components (i.e. of hyperrectangles minus the forbidden region)
- (b) the **program** comprising the possible executions between the minimum of a component, and the minimum of the next
- (c) we use the interleaving semantics for finding 1 path in this program (using 1 , in a very economical manner)

Discretization of paths

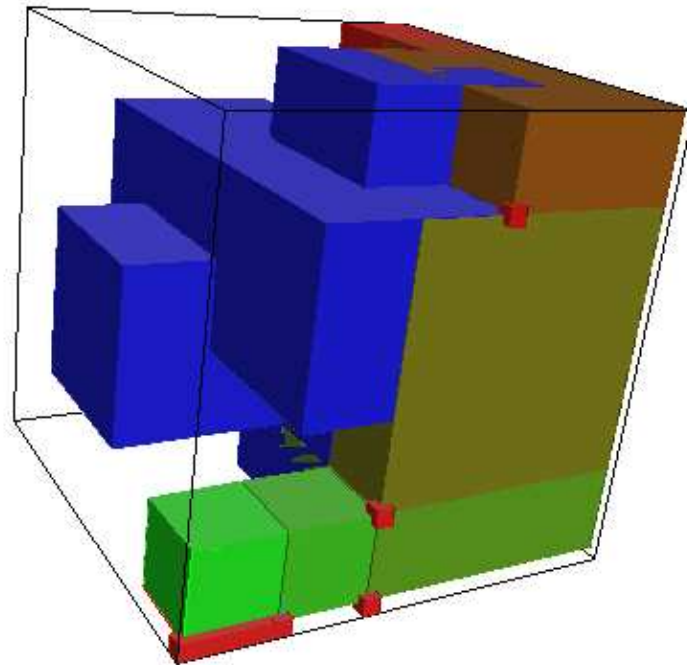

0 | 0 | $P(c)$

In context #sem c 1, #sem b 1, and #sem a 1.

Discretization of paths

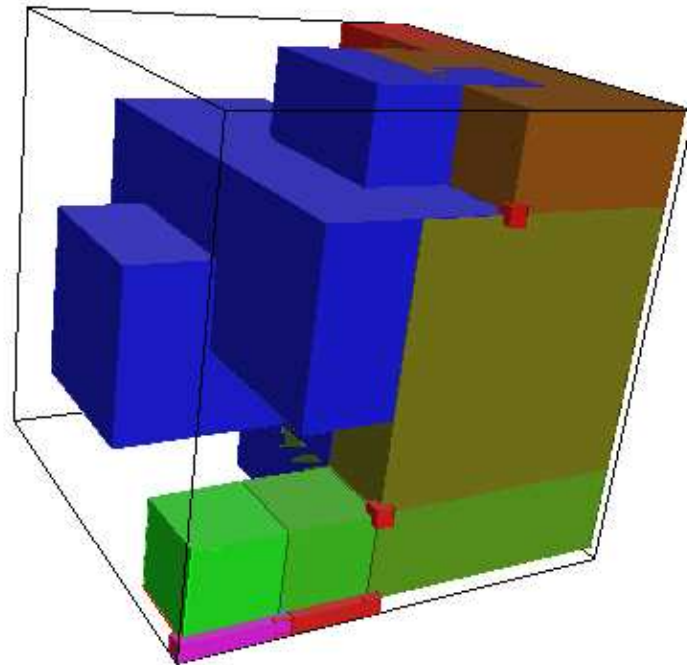

0 | 0 | $P(a)$

In context #sem c 0, #sem b 1, #sem a 1.

Discretization of paths

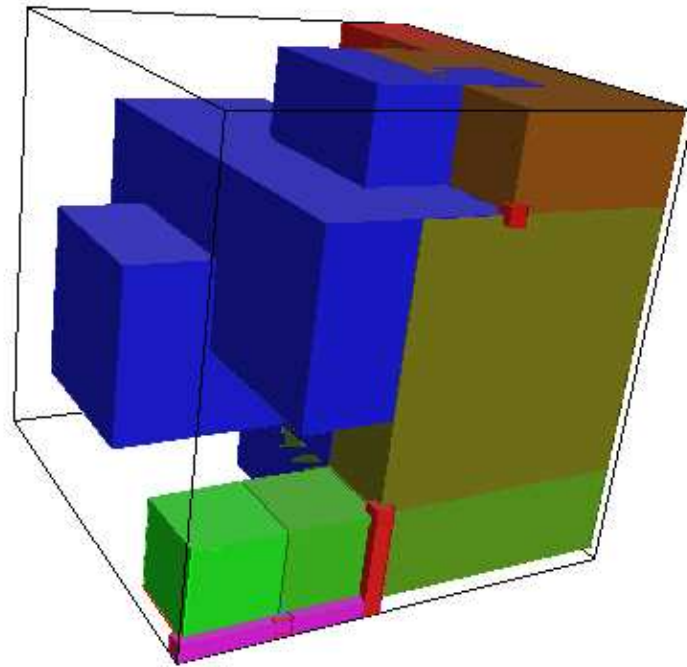

0 | P(b) | 0

In context #sem c 0, #sem b 1, #sem a 0.

Discretization of paths

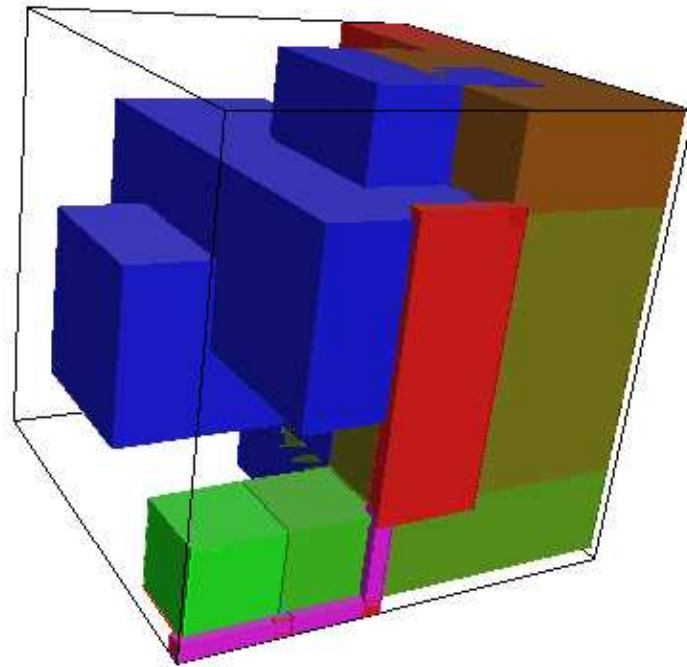

$0 \mid P(c).V(b).V(c) \mid V(c)$

In context #sem c 0, #sem b 0, #sem a 0.

Discretization of paths

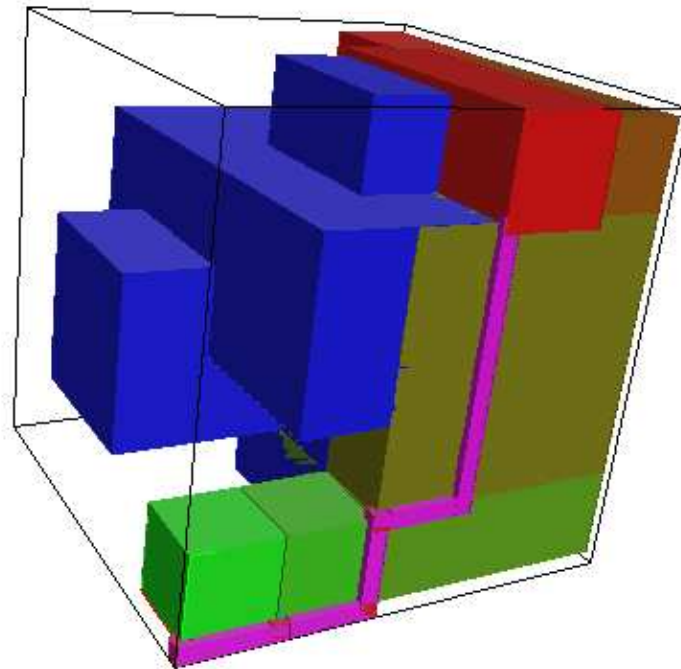

$P(a) . P(b) . V(a) \mid 0 \mid V(a)$

In context #sem c 1, #sem b 1, #sem a 0.

Discretization of paths

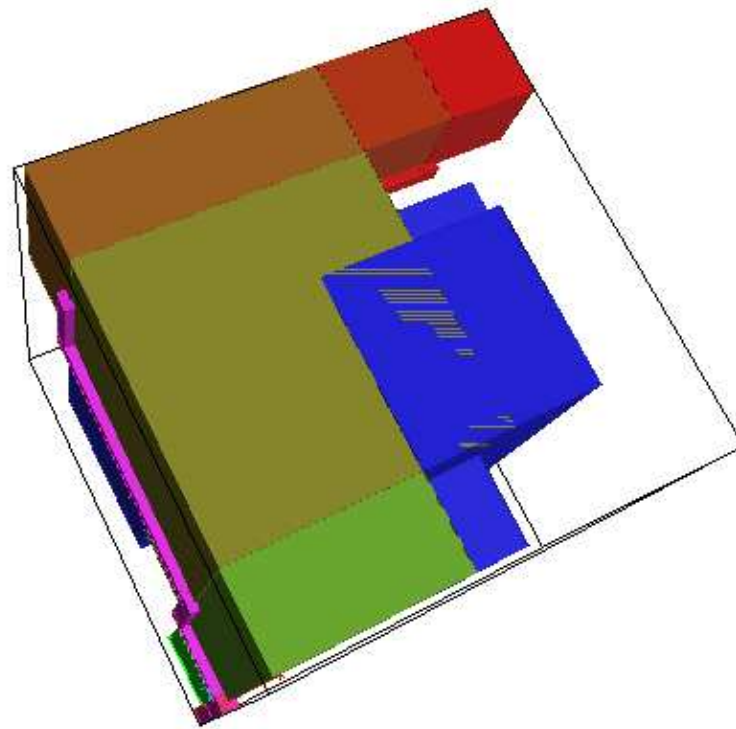

$v(b) \mid 0 \mid 0$

In context #sem c 1, #sem b 0, #sem a 1.

Discretization of paths

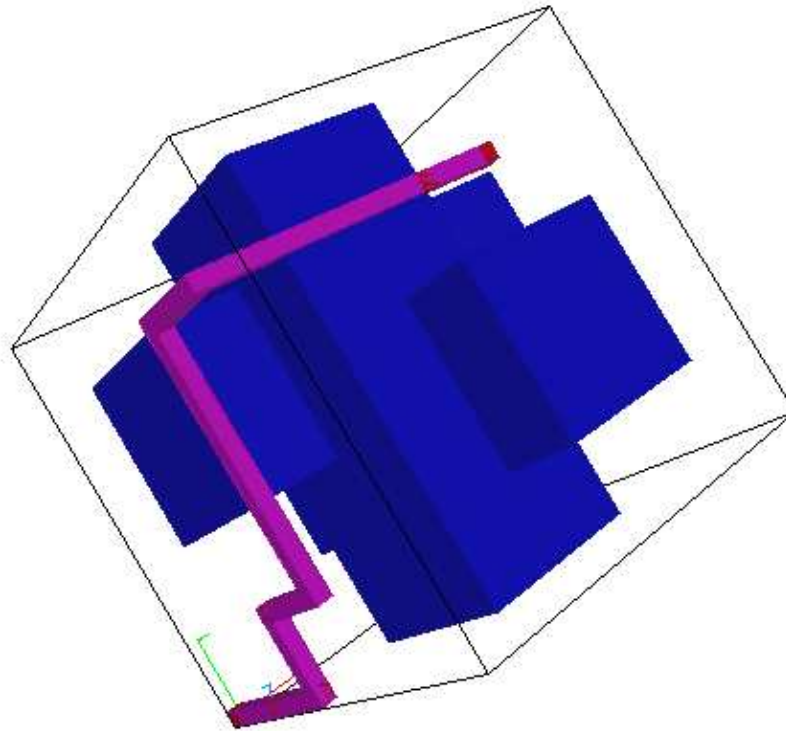

$\{3\}P(c) ; \{3\}P(a) ; \{2\}P(b) ; \{3\}V(c) ; \{2\}P(c) ; \{2\}V(b) ;$
 $\{2\}V(c) ; \{3\}V(a) ; \{1\}P(a) ; \{1\}P(b) ; \{1\}V(a) ; \{1\}V(b) ;$

Discretization of paths (2 - deadlock)

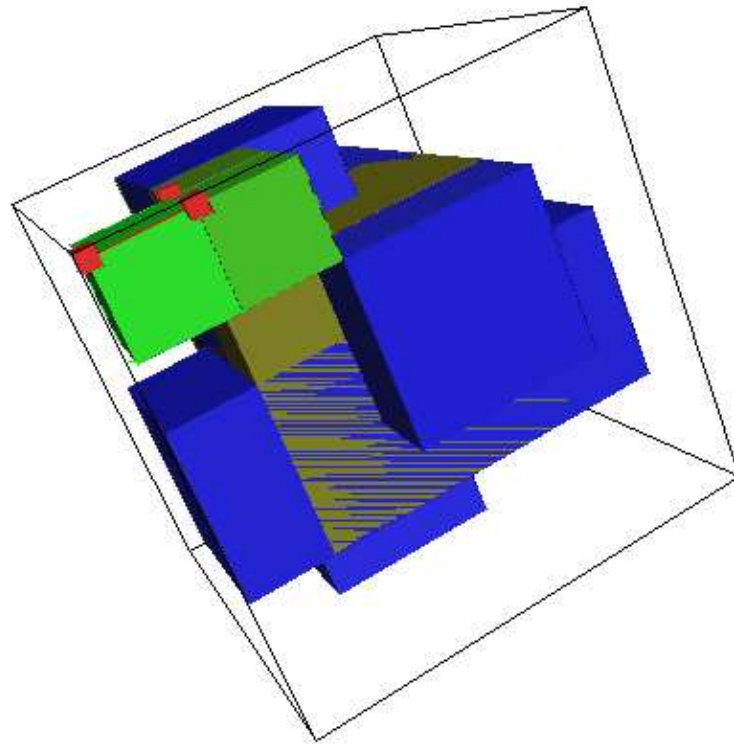

$\{1\}P(a); \{3\}P(c); \{2\}P(b);$

Discretization of paths (3)

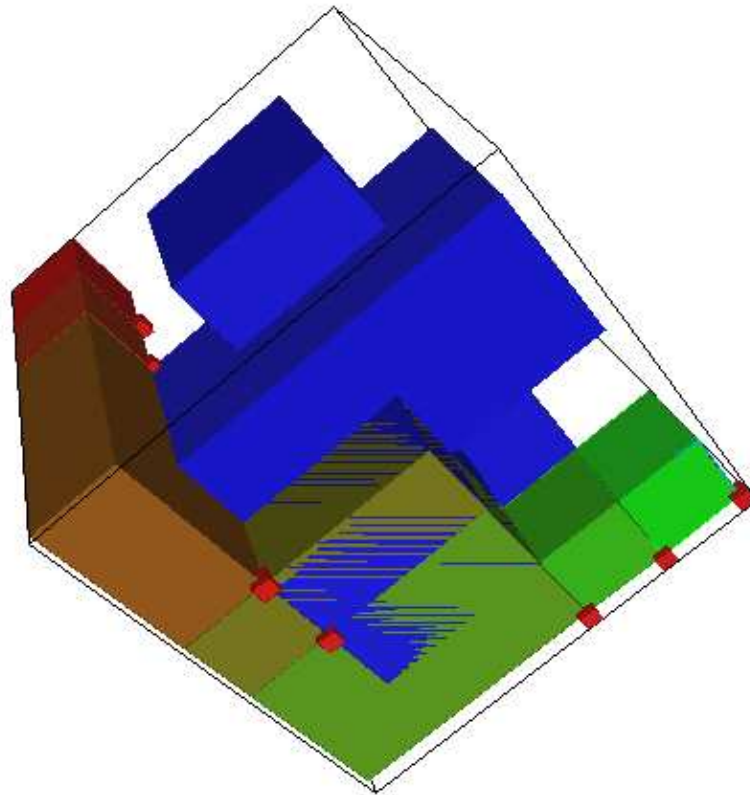

$\{2\}P(b); \{2\}P(c); \{2\}V(b); \{2\}V(c); \{3\}P(c); \{3\}P(a);$
 $\{3\}V(c); \{3\}V(a); \{1\}P(a); \{1\}P(b); \{1\}V(a); \{1\}V(b);$

Discretization of paths (4)

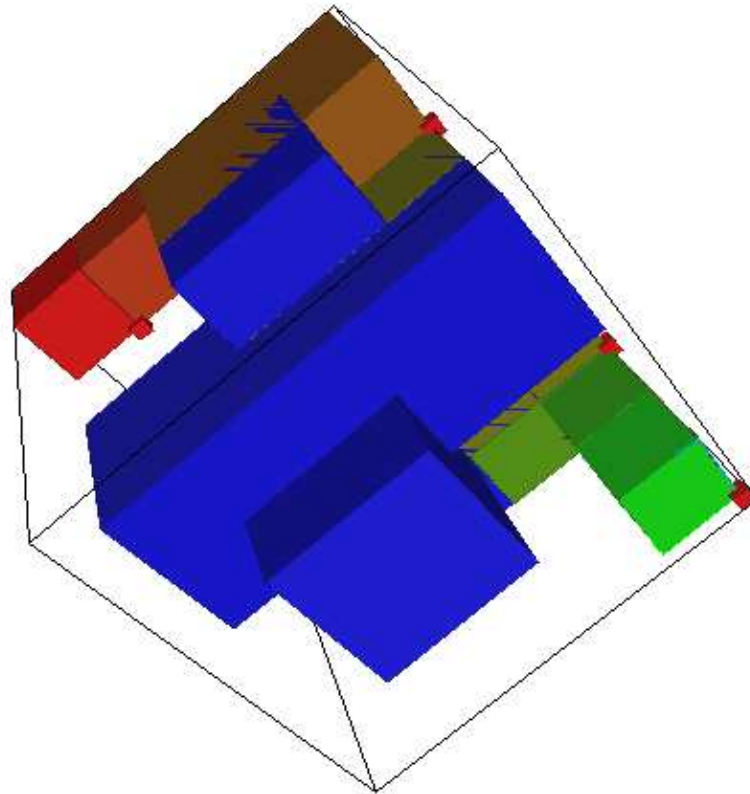

$\{1\}P(a); \{1\}P(b); \{3\}P(c); \{1\}V(a); \{3\}P(a); \{3\}V(c);$
 $\{3\}V(a); \{1\}V(b); \{2\}P(b); \{2\}P(c); \{2\}V(b); \{2\}V(c);$

Discretization of paths (5)

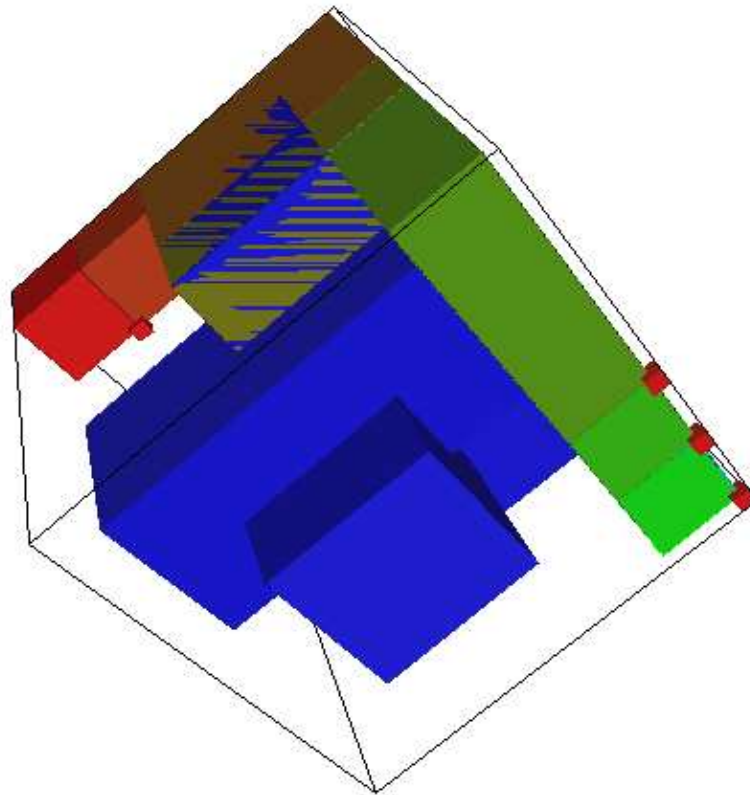

$\{3\}P(c); \{3\}P(a); \{3\}V(c); \{3\}V(a); \{1\}P(a); \{1\}P(b);$
 $\{1\}V(a); \{1\}V(b); \{2\}P(b); \{2\}P(c); \{2\}V(b); \{2\}V(c);$

Discretization of paths (6)

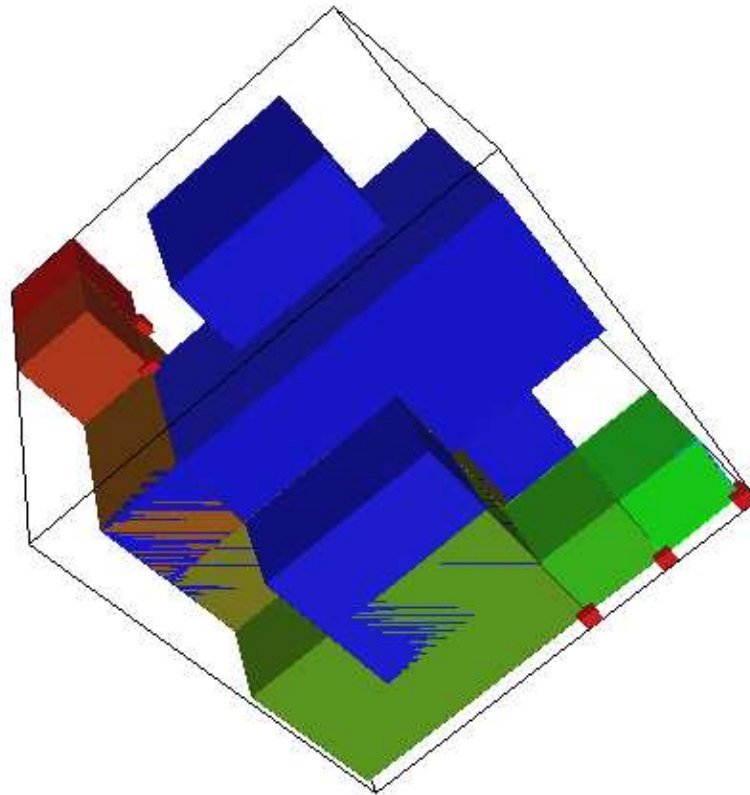

$\{2\}P(b); \{2\}P(c); \{1\}P(a); \{2\}V(b); \{1\}P(b); \{1\}V(a);$
 $\{2\}V(c); \{3\}P(c); \{3\}P(a); \{3\}V(c); \{3\}V(a); \{1\}V(b);$

Discretization of paths (7)

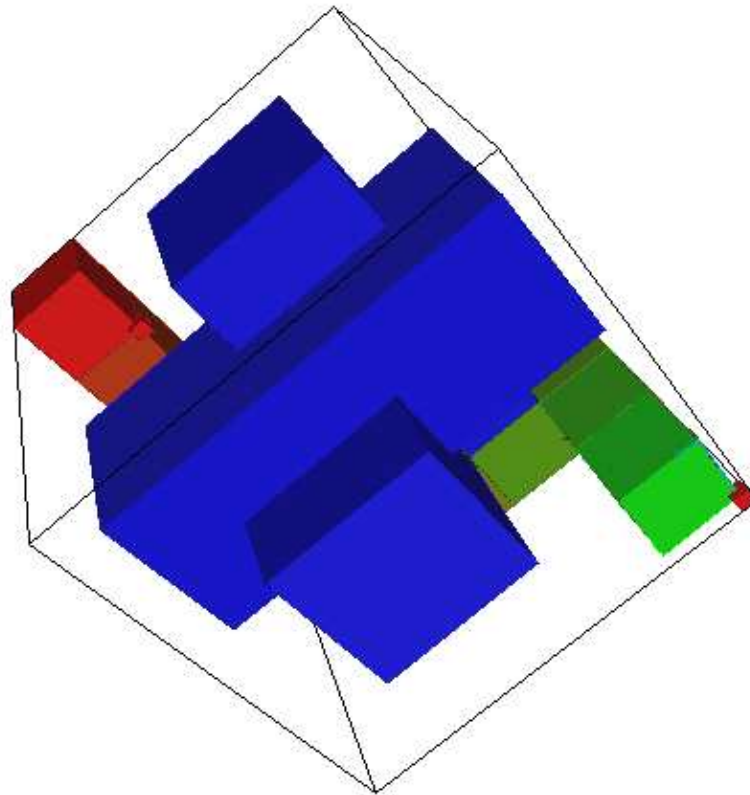

$\{1\}P(a); \{1\}P(b); \{1\}V(a); \{1\}V(b); \{2\}P(b); \{2\}P(c);$
 $\{2\}V(b); \{2\}V(c); \{3\}P(c); \{3\}P(a); \{3\}V(c); \{3\}V(a);$

Component category

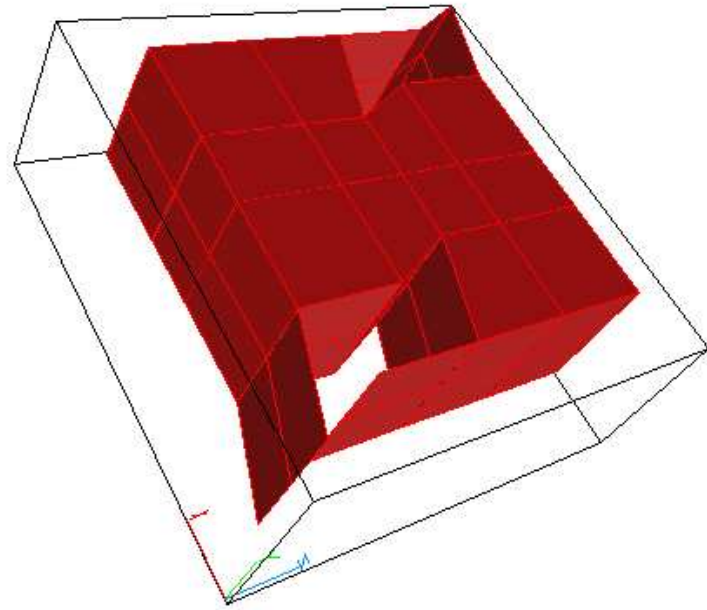
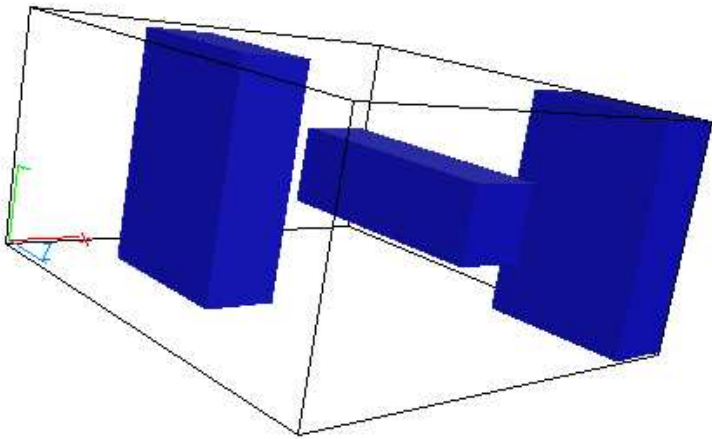

Discretization of paths

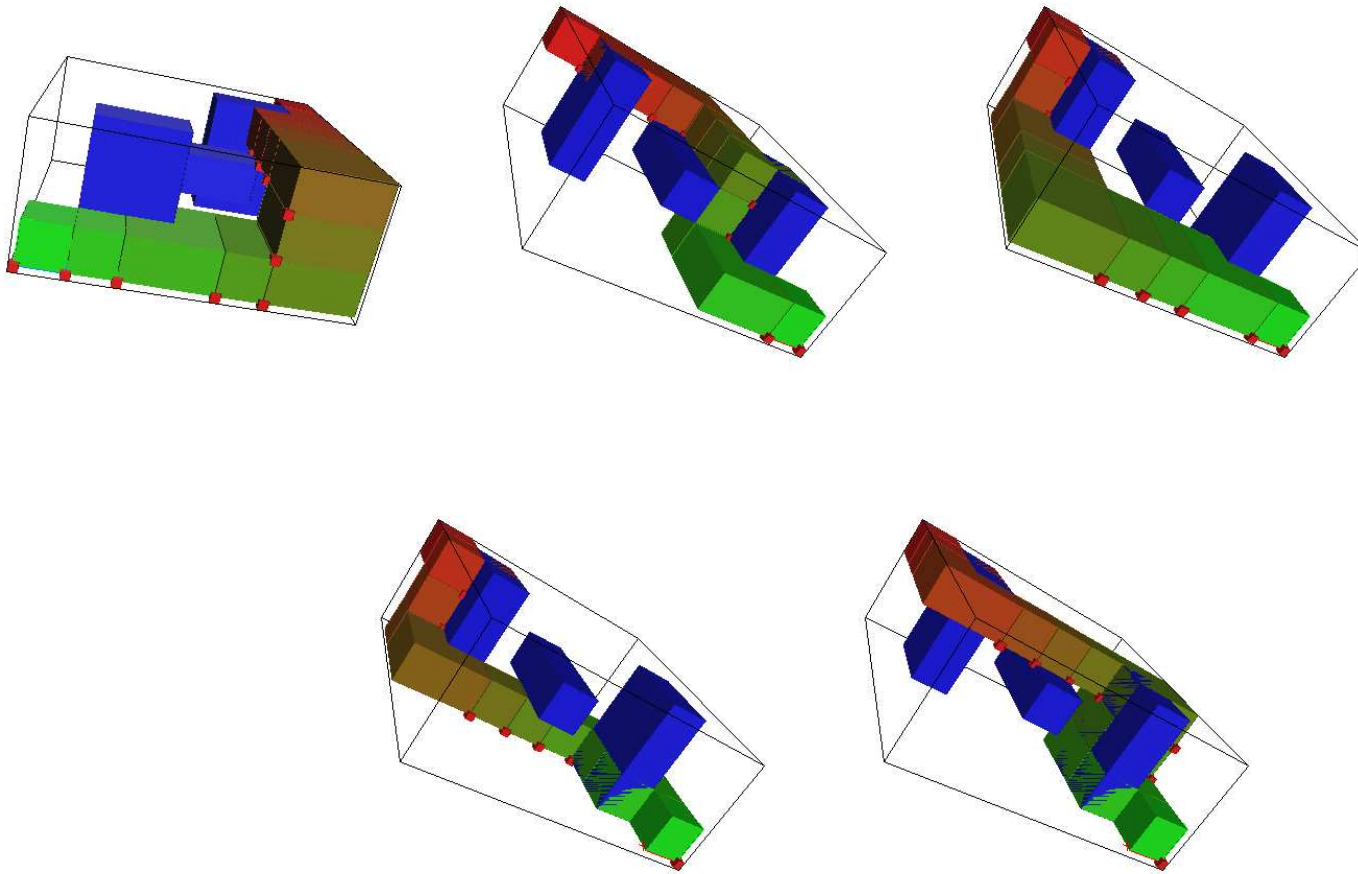

Algorithmic improvements

- Computation of components:
 - still sub-optimal (in size)
 - use of static/dynamic segment trees to improve the computation of intersections
 - (simpler) use of geometric simple geometric constraints to improve the computation of intersections
 - etc.

Algorithmic improvements

- Computation of morphisms in the component category:
 - By computing the first homology group
 - (simpler) approximation of relations (persistent sets)
 - (on the longer run) simplification of the retract by considering also the $\vec{\pi}_n$ [“homotopical resolution”, or “higher-order syzygies”]
- Plus all classical improvements: symbolic terms, symmetry, on the fly traversal, state space hashing etc.

Thanks for your attention...

...Any questions?